

VL-10 TAX STAMP MACHINE



No Measuring - Ideal for Both Post and Pre-Stamping

Uniquely Designed Stamp Cartridge

Superior Stamp Transfer Quality

Easy to Operate

NEW



Left to Right Configuration Shown

Meyercord's VL-10 Tax Stamp Machine gives you quality and flexibility for the future. Ideal for both pre- and post-stamp operations, this machine requires no height adjustments - no more batching sizes ever again! Stamps Regulars, Kings, 100's, 120's and some promotional packs. The VL-10 utilizes a proven stamp head with superior stamp quality transfer. The uniquely designed stamp cartridge makes loading stamps easy and fast - ideal for multi-jurisdiction stamping. Simple to train, easy to operate, and requires low maintenance - the VL-10 Stamp Machine is ideal for your operation.

For Information Contact:
United Silicone
4471 Walden Avenue
Lancaster, New York 14086
Tel: 630 682-6273
Fax: 630 682-6269



An ITW Company

www.meyercordequipment.com

VL-10 TAX STAMP MACHINE

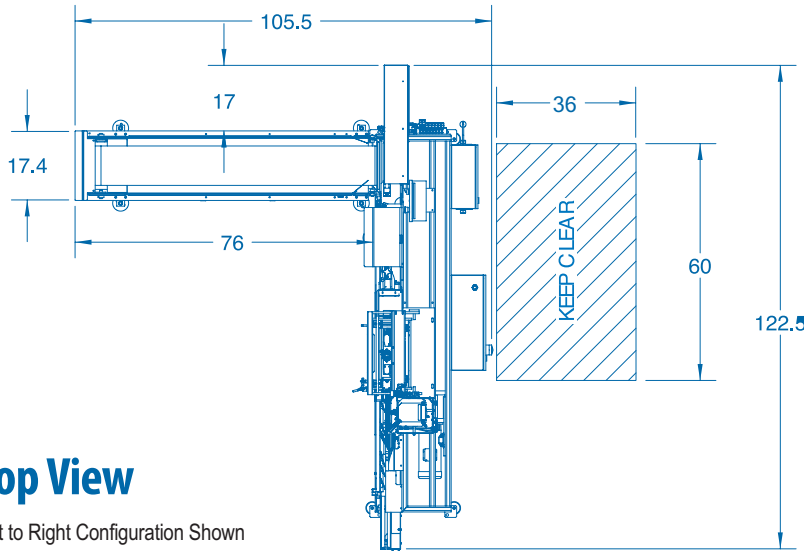

Top View

Left to Right Configuration Shown

Machine Highlights:

- No Adjustments Necessary - Stamps Regulars, Kings, 100's and 120's
- Stamp Cartridge - Quick release and load of stamps
- Stamp Transfer - Superior quality center pack stamping
- Hot Glue System - Precisely applies glue and firmly secures cartons
- Touch-Screen Display - Makes tracking, diagnostics and training easy
- Safety - New Stamp Cartridge design and guarding protects your operators

Side View

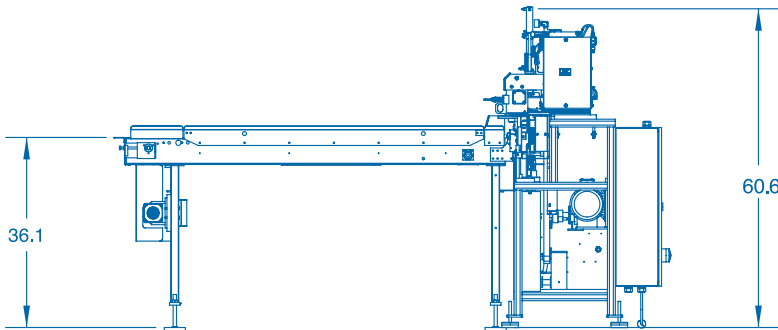

Specifications:

Speed:

Pre-Stamping Mode: 72+ Cartons/Minute
Post-Stamping Mode: 72+ Cartons/Minute

Dimensions:

Length: 10' 3"
Width: 10' 10"
Maximum Machine Height: 5' 1"
In-Feed Conveyor Height: 3' 1"
Machine Weight: 1,250 lbs.
Shipping Weight: 1,500 lbs.

Electrical: 220-230 VAC, 30Amp Single Phase 60Hz

Air: Clean, Dry Air Requirement - 5CFM @ 90psi

Options & Accessories

- Dual Stamp Head
- Meyercord Case Packer
- Lateral Packing Conveyor
- Packing Table
- Angle Drop Table
- Additional Stamp Cartridges
- Compressed Air System

Contact:

Meyercord
Tax Stamping Equipment
Tel: 630 682-6273
Fax: 630 682-6269



An ITW Company

www.meyercordequipment.com