



**MEYERCORD**



**“A”-Type Power Opener**  
Parts Manual (#203615, v2.0)



**Information, Orders, & Technical Support: 1-800-639-3799**

This documentation is protected by United States copyright laws. Copyright 2001 by The Meyercord Company. All rights reserved. Reproduction of material is strictly prohibited without written permission. The Meyercord Company, 365 E. North Avenue, Carol Stream, IL. 60188. Printed in the United States.

## Table of Contents

---

How to use this manual	2
<b>Fig. 1</b>	
Plow assembly	10
<b>Fig. 2</b>	
Torque limiter	12
<b>Fig. 3</b>	
End view	12
<b>Fig. 4</b>	
Top, external	14
<b>Fig. 5</b>	
Top, internal	16
<b>Fig. 6</b>	
Right side	18
<b>Fig. 7</b>	
Bottom, internal	20
<b>Fig. 8</b>	
Feeder, external	22
<b>Fig. 9</b>	
Feeder, internal	24
Master parts list	26

# “A” TYPE POWER OPENER

Product code(s): 19,20

## How to use this manual

1. All components pictured are from an **Adco 120mm Power Opener**. Keep in mind that the pictures are provided as general visual guides. Locating the right part number is as easy as locating the part on the picture and finding its identifying number on the facing parts list. The list will then provide the six digit part number.
2. In order better understand the sections and part descriptions, take a look at the following definitions:



The arrow is used to imply the general location of a part that is partially hidden or too small to be seen easily with a normal line.

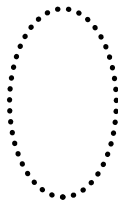

The dotted circle is there to bring your attention to a specified area, and can have two meanings:

- (1) It highlights a group of parts in a small area.
- (2) It represents the location of a part that cannot be seen or is not pictured at all.

3. Throughout this manual, some parts or locations are implied (*'not shown'*). Although they may not be easy to see or are not pictured, they are identified. Look for a number pointing to the part or parts general location, or a combination of numbers that point at one location.
4. You may notice that hardware is occasionally shown with a part number. This is only for special components for which the performance of the machine is dependent on the correct part. All other hardware needs can be purchased at a local hardware store or vendor. The six digit part number is provided so that if there is a question about any dimension, it can be easily located in the parts list. Quantities are provided at the end of the description.

5. For your convenience, the parts are divided into sections for 100 mm and 120 mm ONLY when necessary. At times, 100 mm and 120 mm machines may use different parts, but their location and function are the same. In order for the correct parts (100/120 mm) to be easily located, they are subdivided into sections. (i.e. **1a, 1b**). Any other parts are considered universal.

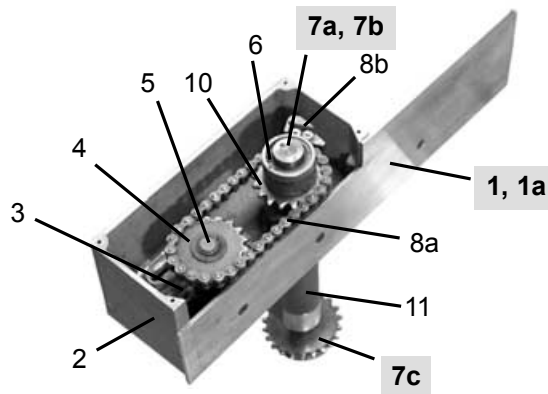

<b><u>100 mm</u></b>	
1a. 169614	GUIDE,CTN FWD
<b><u>120 mm</u></b>	
1b. 191405	GUIDE,CARTON FORWARD
2. 167667 *	FRAME,CTN FORWARD BASE
3. 161210	BRACKET,IDLER STUD
4. 183771	SPROCKET,3/8P,18T,5/8 BORE
5. 184475	STUD,IDLER SPROCKET
6. 157426	TORQUE LIMITER
<b><u>100 mm</u></b>	
7a. 181032 **	SHAFT,CTN FWD DRIVE
<b><u>120 mm</u></b>	
7b. 181890 **	SHAFT,TORQUE LIMITER
7c. 183947 **	SPROCKET,3/8P,22T,1/2 BORE
8a. 163597	CHAIN,UPPER DRIVE
8b. 173387	PAWL,CTN FWD
9. 184068	SPROCKET,3/8P,18T,1 BORE
10. 165082	COVER,DRIVE SPINDLE CHAIN
11. 183100	SPRING,CHUTE ADJ

6. You will notice that on a few occasions, letters are added to the numbers. These parts complement each other, or work together in a mini-assembly, and are grouped together, even though they are physically different. As shown in this example, while **7a-7c** are different parts, their relation to each other is close enough to group them together on the list.

# “A” TYPE POWER OPENER

Product code(s): 19,20

## How to use this manual (cont'd)

7. In order to better understand the sections and part descriptions, take a look at the following definitions:

**Left Hand Unit (LHU, or LH):** cigarette cartons moving from right to left

**Right Hand Unit (RHU, or RH):** cigarette cartons moving from left to right

*(Determined by standing on the operators side and facing the machine)*

### Parts orientation

*(Determined by standing in **front** of the machine and facing the plow)*

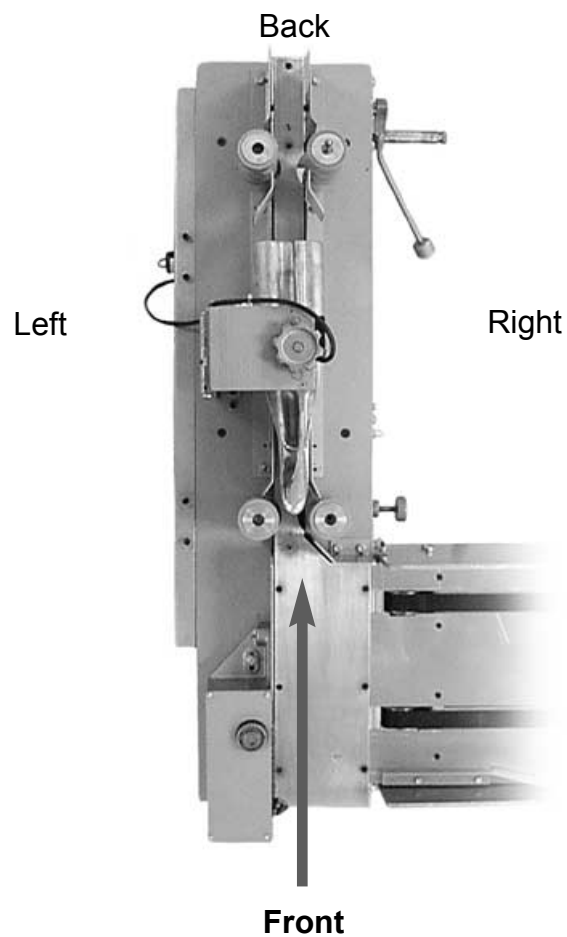

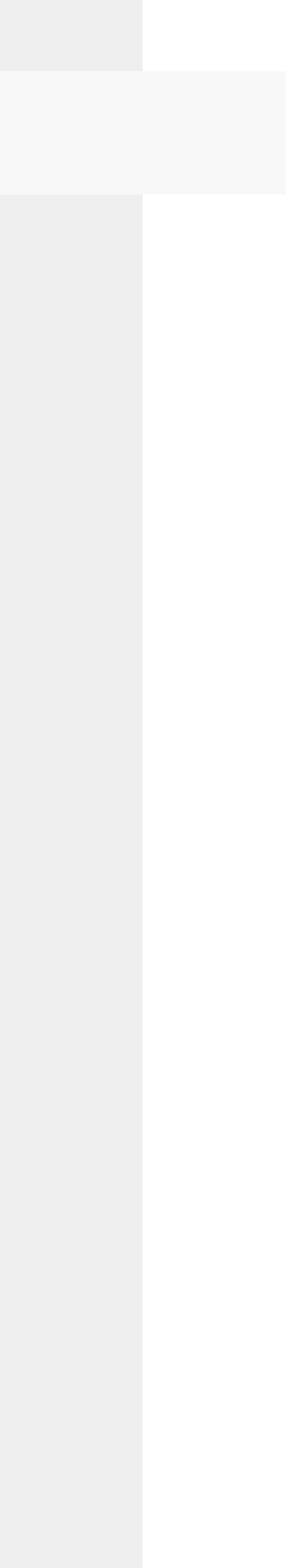

# “A” TYPE POWER OPENER

Product code(s): 19,20

*Figure 1 - Plow assembly* (120 mm pictured)

1.	<b>175345</b>	PLOW, FLAP OPENING
2.	<b>162024</b>	BRACKET,UPPER
3.	<b>161254</b>	BRACKET,LOWER
4.	<b>174113</b>	PLATE,BAR BACKING
5.	<b>156260</b>	ASSEMBLY,HINGE 4181-NRP-26D
6.	<b>170285</b>	HANDLE,ADJ
6a.	<b>177501</b>	ROD,THREAD 1/2-13 X 3IN LG 5/32 HOLE
7.	<b>183320</b>	SPRING,COMP .81 X .082 X 1.61,5 COILS, C&G ENDS
7a.	<b>181164</b>	SHAFT,GUIDE 2-7/8INLG
8.	<b>184871</b>	SWITCH,LIMIT 20AMP
8a.	<b>195277</b>	PIN,MICROSWITCH
8b.	<b>165764</b>	COVER, MICROSWITCH
9.	<b>171792</b>	LEVER,SWITCH
10.	<b>164752</b>	CORD,POWER PLOW
10a.	<b>175565</b>	PLUG,MIDGET NEMA ML-1P 15A 125V
11.	<b>148219</b>	RETAINER,CABLE TIE ANCHOR
11a.	<b>177105</b>	RETAINER,CABLE TIE MEDIUM CLEAR

*Fig. 1*

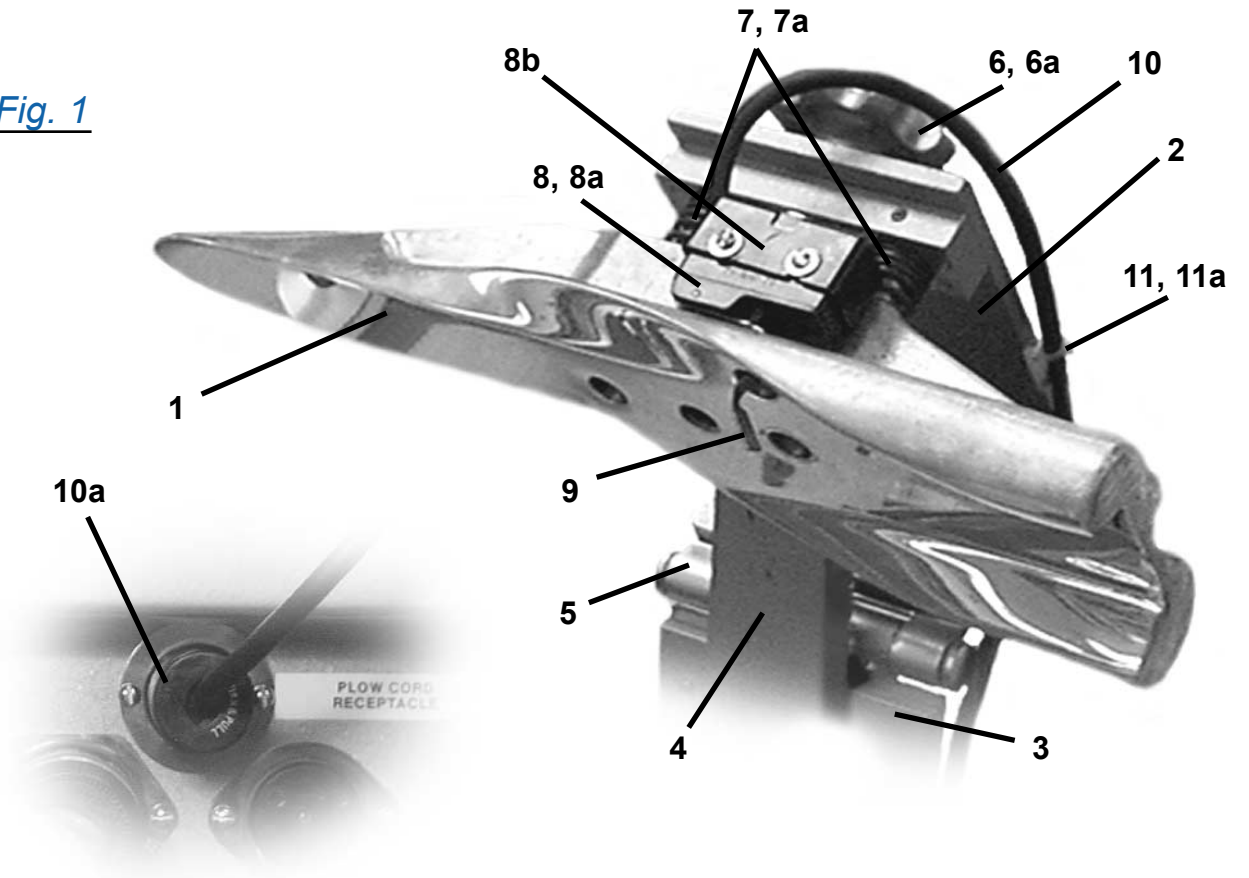

# “A” TYPE POWER OPENER

Product code(s): 19,20

## *Figure 2 - Torque Limiter* (120 mm pictured)

<b><u>100 mm</u></b>		
1a.	<b>169614</b>	GUIDE,CTN FWD
<b><u>120 mm</u></b>		
1b.	<b>191405</b>	GUIDE,CARTON FORWARDING
2.	<b>167667 *</b>	FRAME,CTN FORWARD BASE
3.	<b>161210</b>	BRACKET,IDLER STUD
4.	<b>183771</b>	SPROCKET,3/8P,18T,5/8 BORE
5.	<b>184475</b>	STUD,IDLER SPROCKET
6.	<b>157426</b>	TORQUE LIMITER
<b><u>100 mm</u></b>		
7a.	<b>181032 **</b>	SHAFT,CTN FWD DRIVE
<b><u>120 mm</u></b>		
7b.	<b>181890 **</b>	SHAFT,TORQUE LIMITER
7c.	<b>183947 **</b>	SPROCKET,3/8P,22T,1/2 BORE
8a.	<b>163597</b>	CHAIN,UPPER DRIVE
8b.	<b>173387</b>	PAWL,CTN FWD
9.	<b>184068</b>	SPROCKET,3/8P,18T,1 BORE
10.	<b>165082</b>	COVER,DRIVE SPINDLE CHAIN
11.	<b>183100</b>	SPRING,CHUTE ADJ
12.	<b>163553</b>	CHAIN,LOWER DRIVE

\* Specify left hand right hand machine when ordering. If you don't know, look to #5 on p. 5 for help.

\*\* 7a and 7b must be ordered together as an assembly.

## *Figure 3 - Front end, interior* (120 mm shown)

These views are provided to assist in understanding the differences between what a right hand machine (unit) and left hand machine (unit) look like.

*Fig. 2*

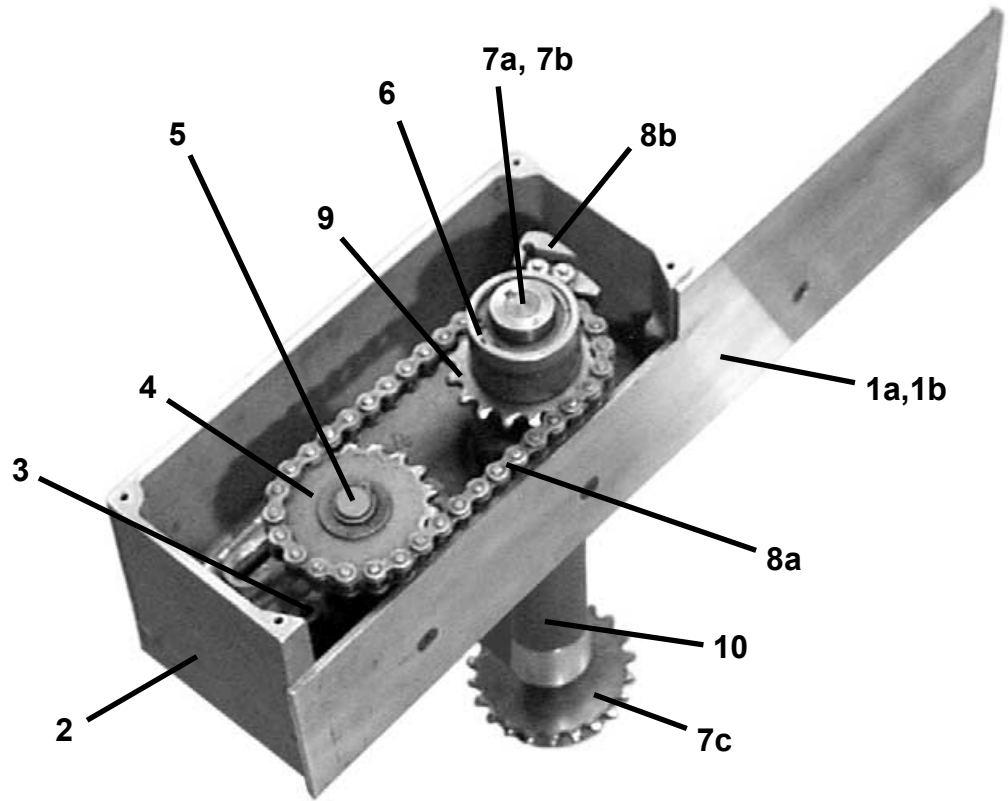

Right hand unit

*Fig. 3*

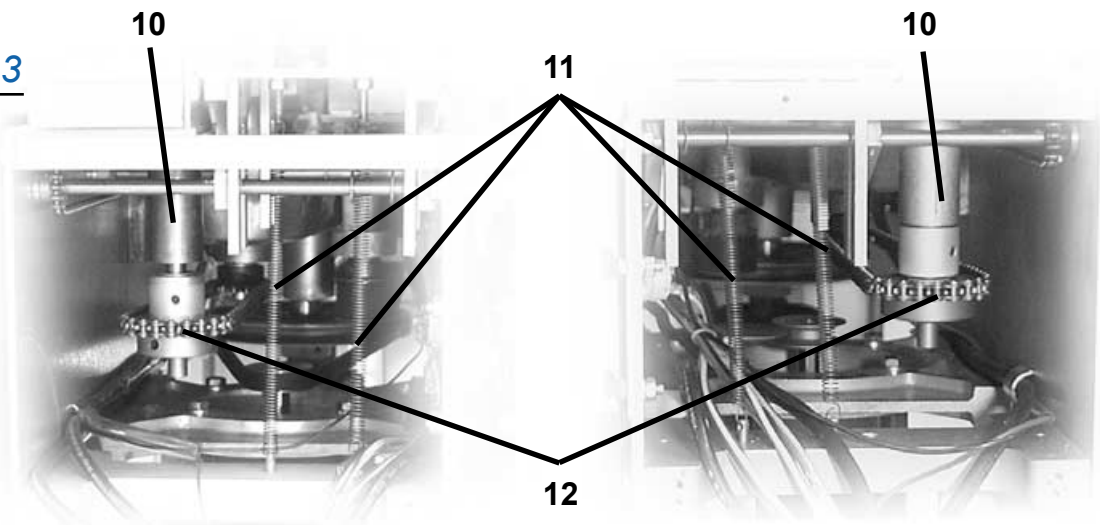

Right hand unit

Left hand unit

# “A” TYPE POWER OPENER

Product code(s): 19,20

*Figure 4 - Top, external* (120 mm pictured)

<u>100 mm</u>	
1a.	<b>191482</b> GUIDE,RHU DISCHARGE CTN LEFT
1b.	<b>191460</b> GUIDE,RHU DISCHARGE CTN RIGHT
<u>120 mm</u>	
1c.	<b>170098</b> GUIDE,RHU DISCHARGE CTN LEFT
1d.	<b>170109</b> GUIDE,RHU DISCHARGE CTN RIGHT
<u>100mm</u>	
2a.	<b>177589</b> ROLLER,CORE
<u>120mm</u>	
2b.	<b>199039</b> ROLLER, CARTON FORWARDING
2c.	<b>177655</b> ROLLER,CORE -141
<u>100 mm</u>	
3a.	<b>169988</b> GUIDE,LEFT SIDE CTN
3b.	<b>169702</b> GUIDE,RIGHT SIDE CTN
<u>120 mm</u>	
3c.	<b>170120</b> GUIDE,LEFT SIDE CTN
3d.	<b>189689</b> GUIDE,RIGHT SIDE CTN
<u>100 mm</u>	
4a.	<b>169779</b> GUIDE,RHU FEED END CTN
4b.	<b>191416</b> GUIDE,LHU FEED END CTN
<u>120 mm</u>	
4c.	<b>108047</b> GUIDE,RHU FEED END CTN
4d.	<b>169592</b> GUIDE,LHU FEED END CTN
5.	<b>176291</b> RAIL,CTN HEIGHT ADJ
6.	<b>164939</b> COVER,CTN FORWARD BASE
7.	<b>176511</b> RECEPTACLE,FLANGED NEMA NOT 10A 250V / 15A 125V
8.	<b>175587</b> PLUG,MALE HUBBELL 7567 C
9.	<b>147427</b> RECEPTACLE,2 PRONG NEMA ML2 15A 125V
10.	<b>175565</b> PLUG,MIDGET NEMA ML-1P 15A 125V
11.	<b>176489</b> RECEPTACLE,FLANGED NEMA ML-1R 15A 125V
12.	<b>178513</b> SCREW,FRONT RLR SPRING
13.	<b>164961</b> COVER,CHAIN

*Fig. 4*

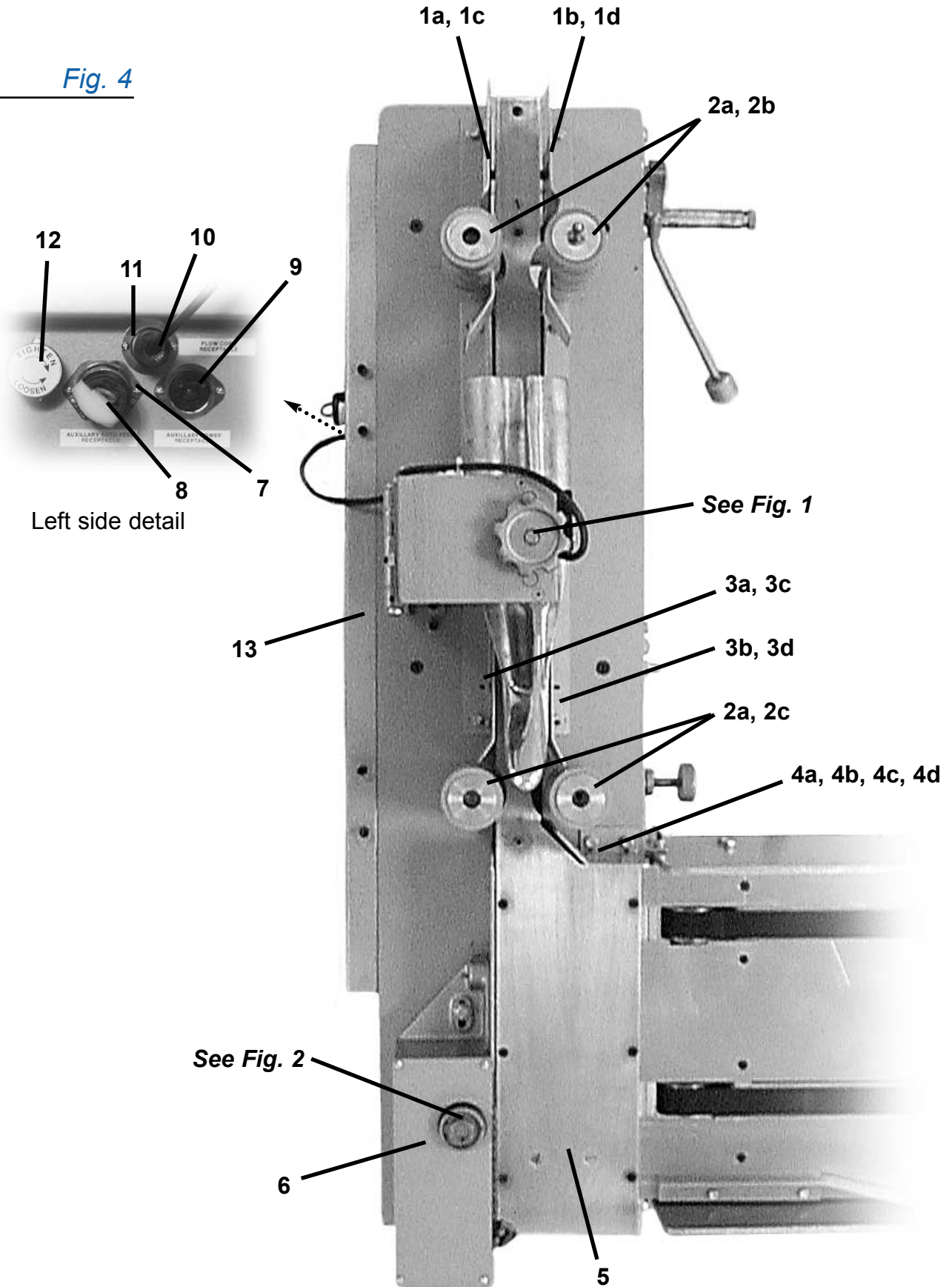

# “A” TYPE POWER OPENER

Product code(s): 19,20

## *Figure 5 - Top, internal* (120 mm pictured)

1a.	<b>163157</b>	CAM,ADJ CHUTE 1IN
1b.	<b>180603</b>	SHAFT,ADJ CHUTE CAM
1c.	<b>162695</b>	BUSHING,BRASS CAM SHAFT
	<b><u>100mm</u></b>	
2a.	<b>157481</b>	ASSEMBLY,TRANS LH, 100MM
2b.	<b>157492</b>	ASSEMBLY,TRANS RH, 100MM
	<b><u>120 mm</u></b>	
2c.	<b>199677</b>	ASSEMBLY,TRANS LH, 120MM
2d.	<b>199688</b>	ASSEMBLY,TRANS RH, 120MM
3.	<b>156744</b>	SPRING,PRIMARY TRANS ARM
4a.	<b>176115</b>	PULLEY,MOTOR REG ( <i>Handstamper</i> )
4b.	<b>176104</b>	PULLEY,MOTOR FAST ( <i>Automatic</i> )
5a.	<b>163168</b>	CAM,ADJ CHUTE 3/8IN
5b.	<b>180625</b>	SHAFT,ADJ CHUTE CAM 10-7/8 LG
5c.	<b>180614</b>	SHAFT,ADJ CHUTE CAM 10-3/4 LG
6a.	<b>164356</b>	COUPLING,LH THREAD ( <i>Chain tensioner</i> )
6b.	<b>177446</b>	ROD,HEX THREADED ( <i>Chain tensioner</i> )
7.	<b>198049</b>	CHAIN, RAIL ADJ INTERNAL #25 1/4" 67 LINKS
8.	<b>183760</b>	SPROCKET,ADJ CHUTE CHAIN
9.	<b>163553</b>	CHAIN,LOWER DRIVE
10.	<b>198060</b>	CHAIN, RAIL ADJ EXTERNAL #25 1/4" 245 LINKS

*Fig. 5*

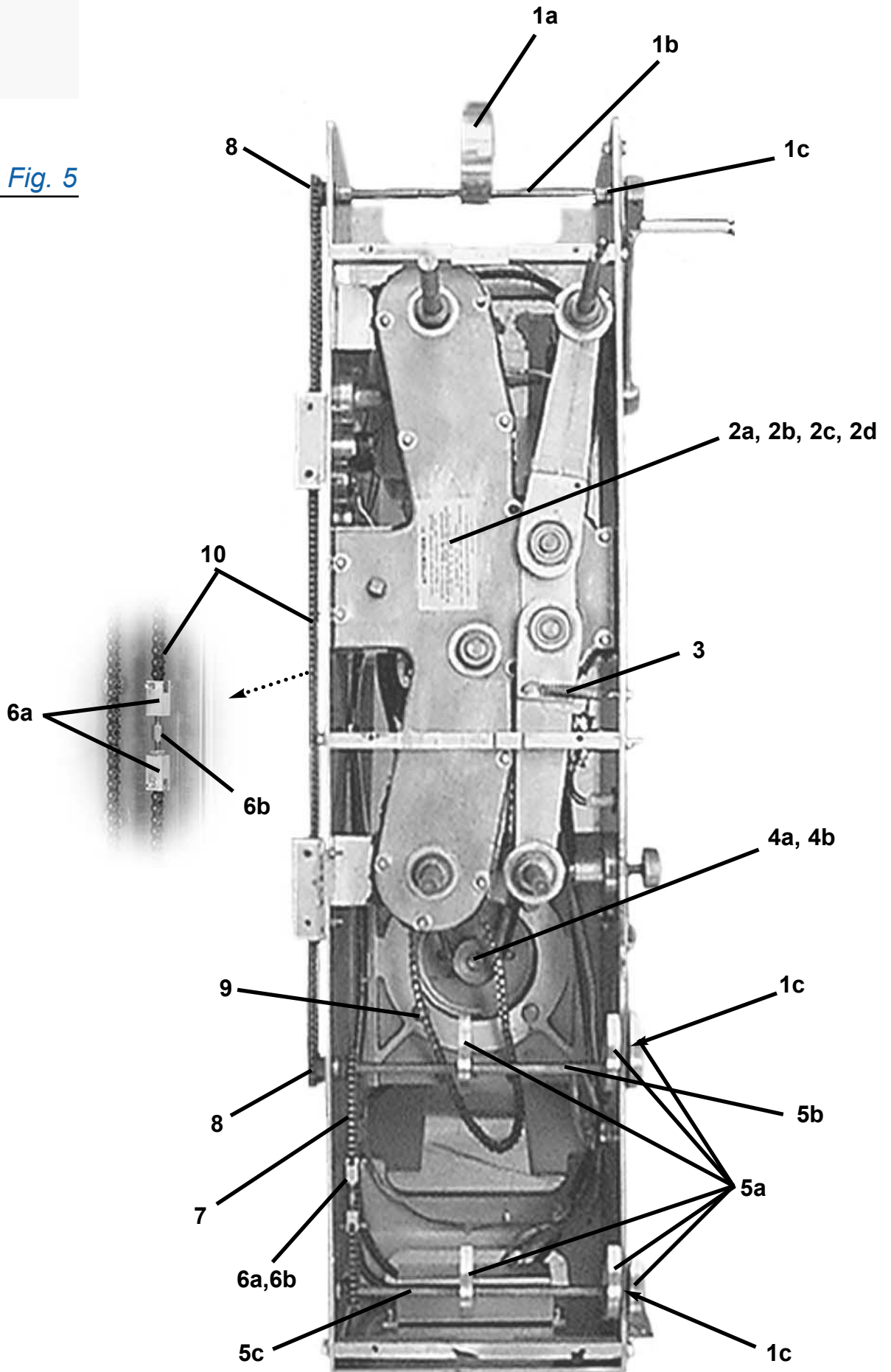

# “A” TYPE POWER OPENER

Product code(s): 19,20

*Figure 6 - Right side* (120 mm pictured)

- |      |               |                                       |
|------|---------------|---------------------------------------|
| 1.   | <b>182264</b> | SLEEVE,MEDIUM RUBBER                  |
| 2.   | <b>170571</b> | HANDLE,KNOB RLR SPINDLE TRANS         |
| 3.   | <b>195849</b> | SLEEVE,POLYURETH,1.25X1.88X.76,ORANGE |
| 4.   | <b>174850</b> | PLATE,RAIL ADJ                        |
| 5.   | <b>113602</b> | ASSEMBLY,HANDLE CHUTE ELEVATING       |
| 6.   | <b>171583</b> | ASSEMBLY,LEVER,CTN HEIGHT ADJ         |
| 7.   | <b>191471</b> | KNOB,LEVER ADJ                        |
| 8.   | <b>193000</b> | SWITCH,BYPASS FEEDER,1P-2T            |
| 9.   | <b>162354</b> | BULB,10-19MA 110V RED                 |
| 10.  | <b>178997</b> | SCREW,PRESSURE ADJ REAR RLR           |
| 11.  | <b>172089</b> | MOTOR,1/3HP LEESON                    |
| 12.  | <b>153620</b> | SPRING,CTN LOCATING 3 HOLES           |
| 12a. | <b>178425</b> | SCREW,FKHM 8-32 X 3/8 (Sets of 2)     |
| 12b. | <b>146701</b> | NUT,HEX NYLOK 8-32 (Sets of 2)        |

*Fig. 6*

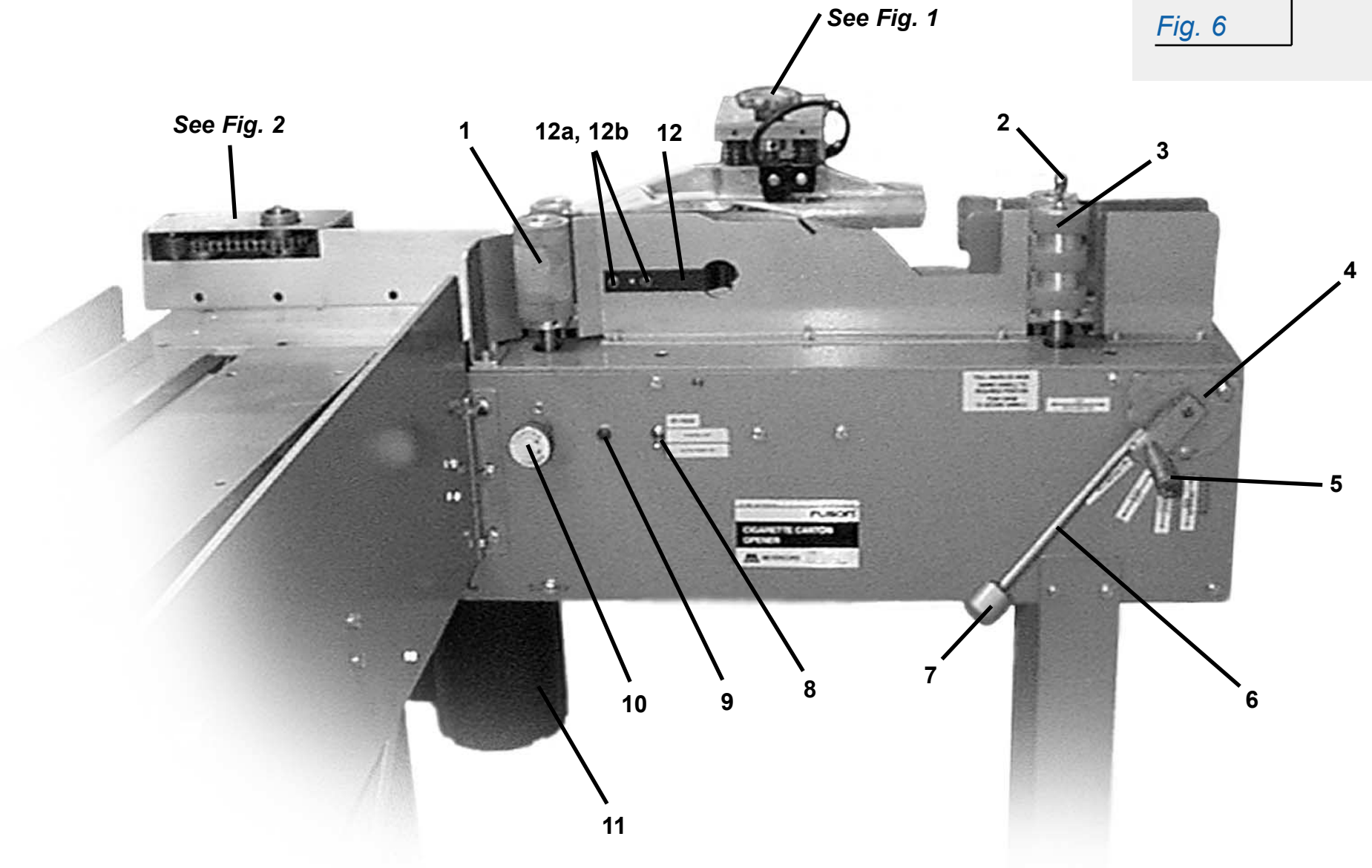

# “A” TYPE POWER OPENER

Product code(s): 19,20

## *Figure 7 - Bottom internal* (120 mm pictured)

---

1.	<b>172584</b>	MOUNT,MOTOR
2.	<b>158878</b>	BELT,210L100
3a.	<b>156964</b>	SPRING,SECONDARY ADJ KNOB
3b.	<b>177204</b>	RETAINER,SPRING
4.	<b>180229</b>	SEAL,RUBBER CLUTCH TIP TRANS
5a.	<b>160517</b>	BRACKET,ADJ SCREW
5b.	<b>157316</b>	ASSEMBLY,TENSION ADJ INSERT
6a.	<b>158658</b>	BELT,4L370 ( <i>Reg, Handstamper</i> )
6b.	<b>158669</b>	BELT,4L380 ( <i>Speed, Automatic</i> )
7.	<b>163553</b>	CHAIN,LOWER DRIVE
8.	<b>183804</b>	SPROCKET,3/8P,13T,1/2 BORE ( <i>35B13</i> )
9.	<b>175576</b>	PLUG,MIDGET NEMA ML-3P 15A 125/250V

*Fig. 7*

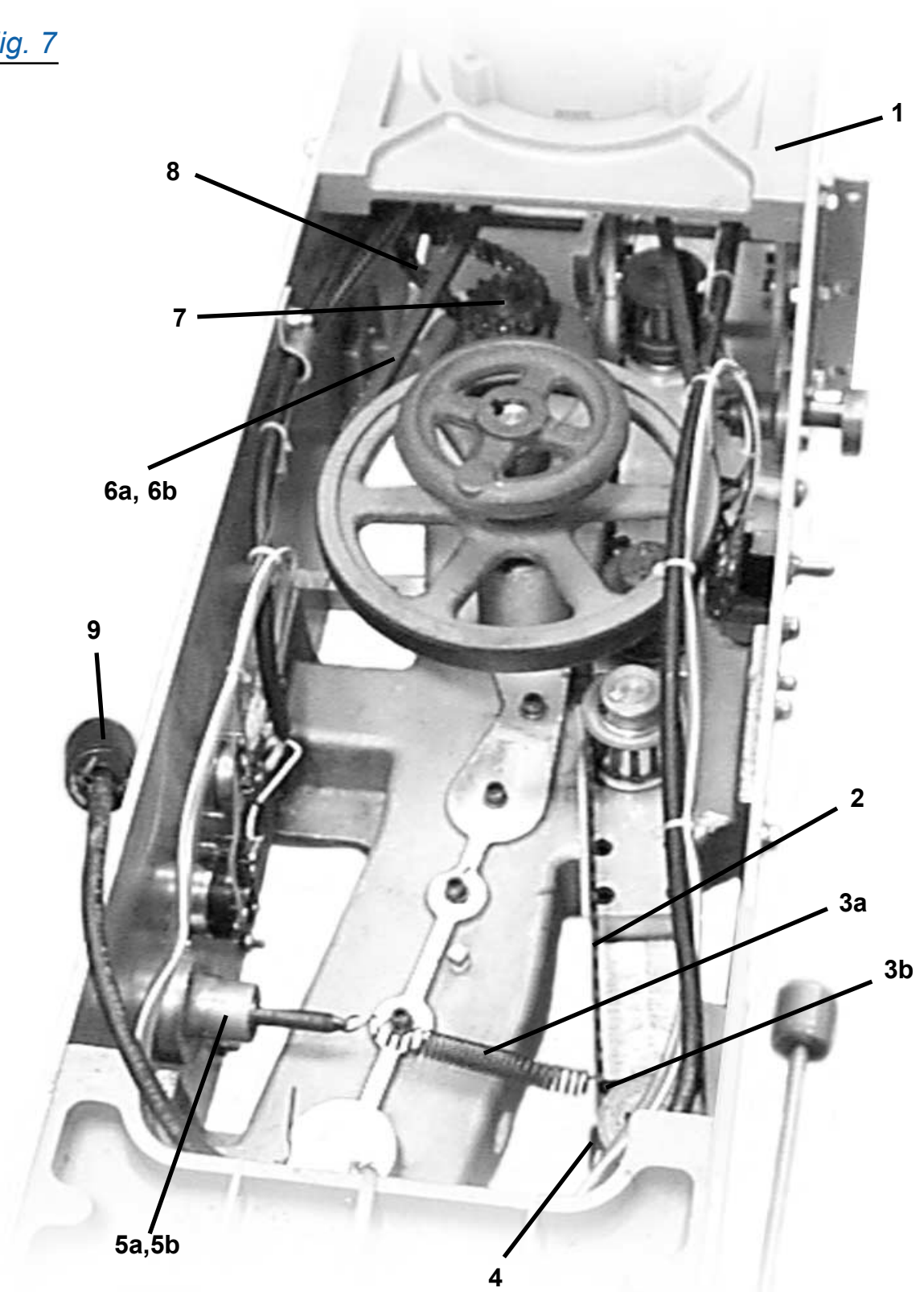

# “A” TYPE POWER OPENER

Product code(s): 19,20

## *Figure 8 - Feeder, external* (120 mm pictured)

---

- |     |               |                               |
|-----|---------------|-------------------------------|
| 1.  | <b>174333</b> | PLATE,CONVEYOR REAR TOP       |
| 2.  | <b>174300</b> | PLATE,CONVEYOR CENTER TOP     |
| 3.  | <b>174608</b> | PLATE,FRONT TOP CONVEYOR      |
| 4.  | <b>158889</b> | BELT,600L100                  |
| 4a. | <b>169460</b> | GUIDE,CONVEYOR BELT 2, TEFLON |
| 5.  | <b>169482</b> | GUIDE,CONVEYOR CTN            |
| 5a. | <b>195838</b> | GUIDE,LH CONVEYOR CTN         |
| 6.  | <b>178425</b> | SCREW,FKHM 8-32 X 3/8         |

*Fig. 8*

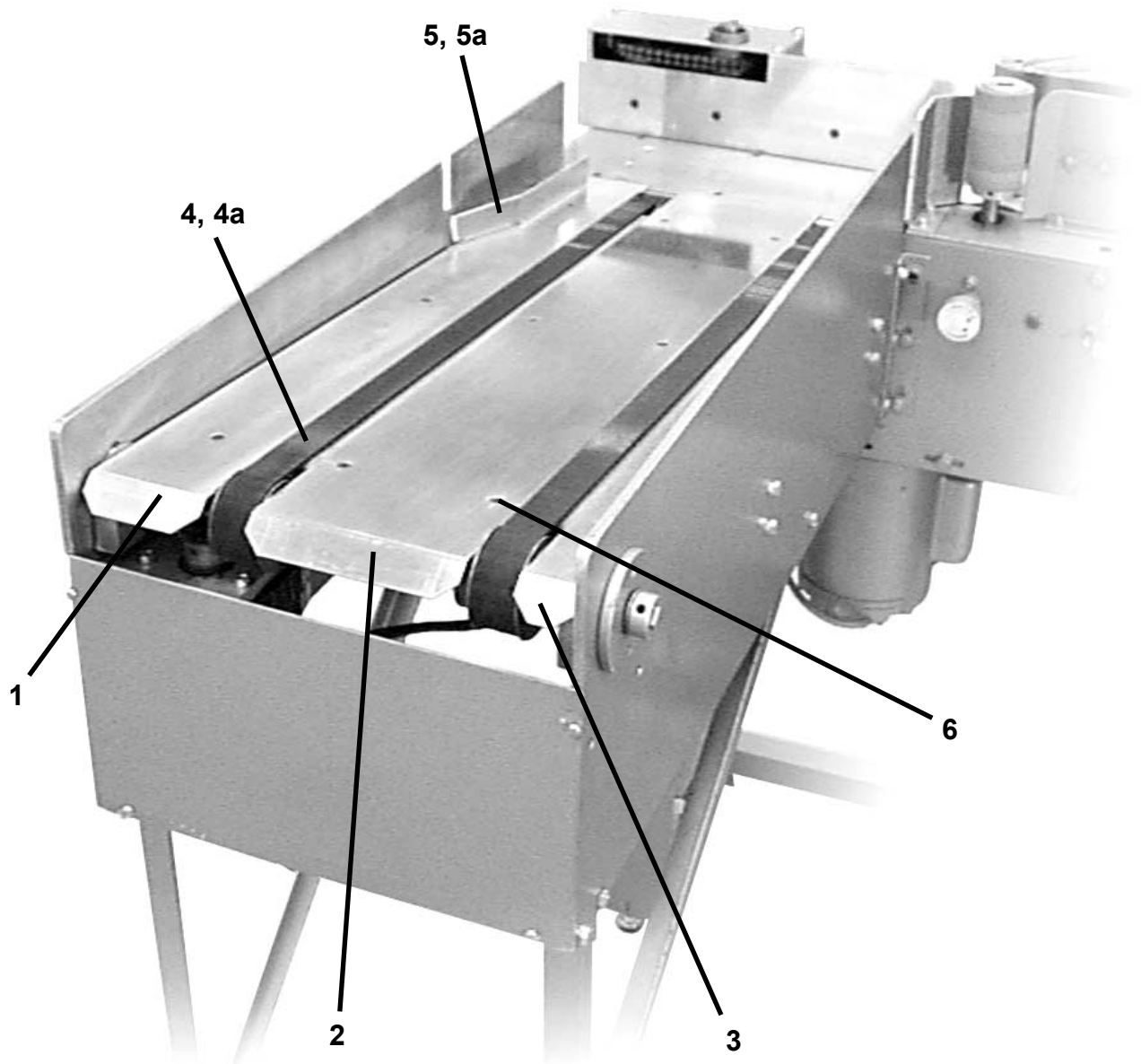

# “A” TYPE POWER OPENER

Product code(s): 19,20

## *Figure 9 - Feeder, internal* (120 mm pictured)

---

- |     |               |  |
|-----|---------------|--|
| 1.  | <b>168382</b> | GEAR,BEVEL STEEL 20T,16DP,7/6 BORE     |
| 2.  | <b>172705</b> | MOUNT,SPINDLE BEARING                  |
| 2a. | <b>152047</b> | BEARING,BALL .50 X1.13 X .38 2 SHEILDS |
| 3.  | <b>187720</b> | WASHER,SPACER                          |
| 4.  | <b>162739</b> | BUSHING,FEEDER                         |
| 5.  | <b>175950</b> | PULLEY,CONVEYOR BELT DRIVE             |
| 6.  | <b>175961</b> | PULLEY,CONVEYOR BELT DRIVEN            |
| 7.  | <b>180911</b> | SHAFT,CONVEYOR DRIVE                   |
| 8.  | <b>147427</b> | RECEPTACLE,2 PRONG NEMA ML2 15A 125V   |
| 9.  | <b>169449</b> | GUIDE,CONVEYOR BELT 1                  |
| 9a. | <b>169460</b> | GUIDE,CONVEYOR BELT 2, TEFLON          |
| 10. | <b>172056</b> | MOTOR,GEAR 1/20HP                      |
| 11. | <b>189645</b> | PULLEY,CONVEYOR BELT IDLER             |
| 12. | <b>180900</b> | SHAFT,CONVEYOR BELT IDLER              |
| 13. | <b>169790</b> | GUIDE,FEEDER BELT                      |
| 14. | <b>103636</b> | SCREW,SHC 1/4-20 X 1-1/4               |
| A.  | <b>200403</b> | Assembly,Feeder Motor                  |

Fig. 9

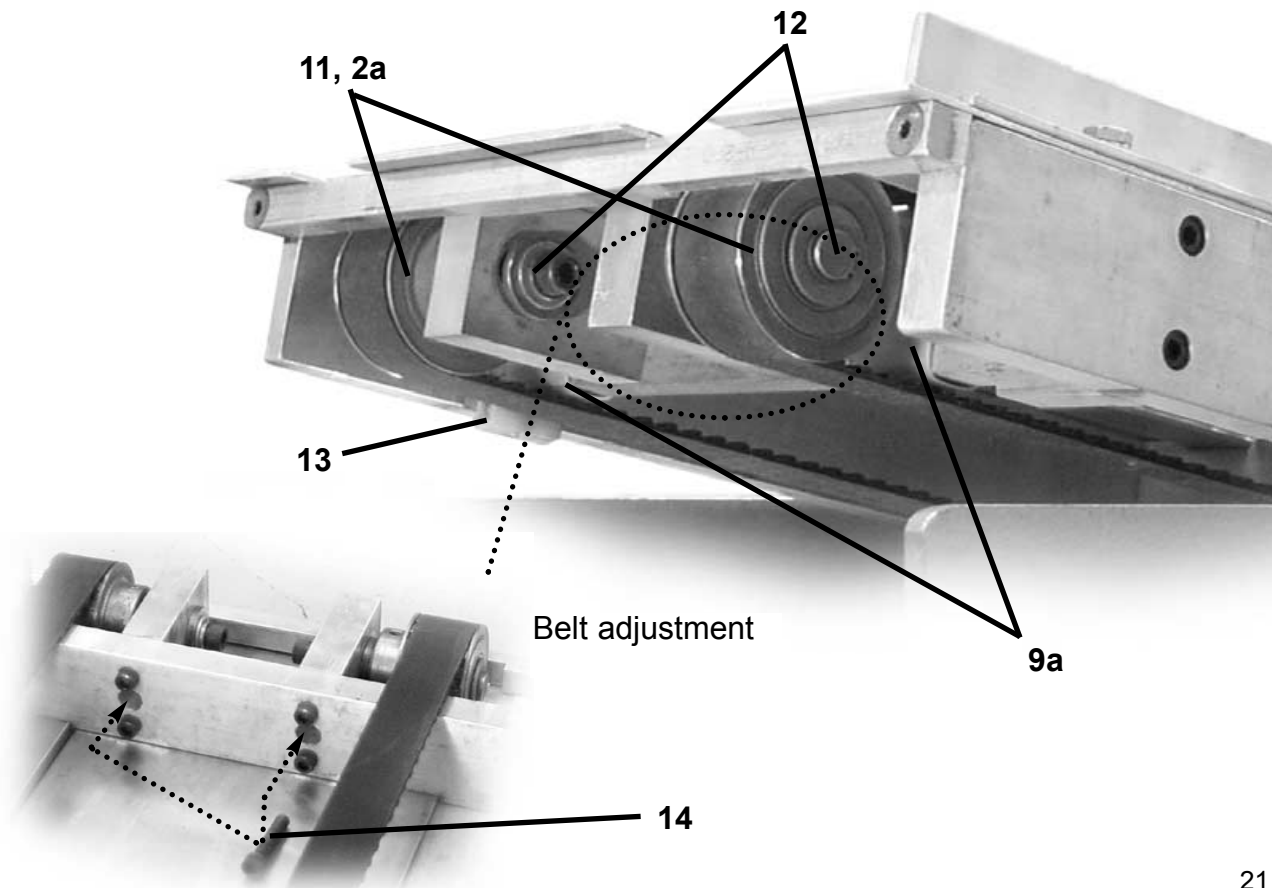
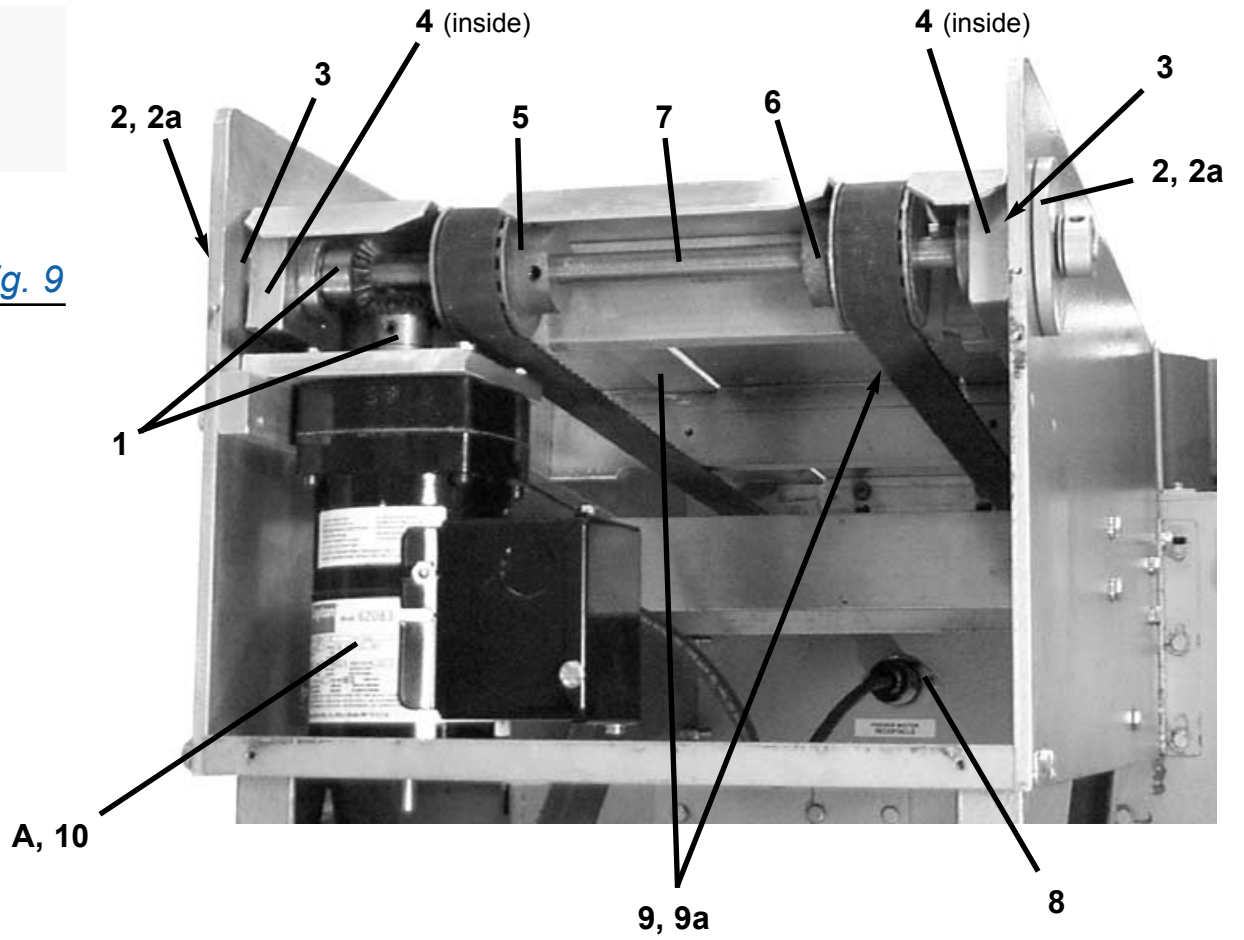

# “A” TYPE POWER OPENER

Product code(s): 19,20

## Master parts list (Alphabetically by description)

<u>Description</u>	<u>New #</u>	
<b>Product codes 19,20: 100mm and 120mm</b>		
ARM,LEFT CONVEYOR	154511	
ARM,RIGHT CONVEYOR	154621	
ARM,TRANS FEED RLR TRANS	154654	
ASSEMBLY,ADJ KNOB	154709	
ASSEMBLY,ARM W/BEARING TRANS	154764	
ASSEMBLY,CAM SHAFT	155116	
ASSEMBLY,CONVERSION HARNESS	155336	
ASSEMBLY,CONVEYOR CROSS BRACE	155347	
ASSEMBLY,CONVEYOR PULLEY	155380	
ASSEMBLY,CORD INTERFACE	155402	
ASSEMBLY,CORD W/SWITCH	155435	
ASSEMBLY,HANDLE CHUTE ELEVATING	113602	
ASSEMBLY,IDLER SPUR 1-1/4 LG	156315	
ASSEMBLY,IDLER SPUR 1-3/4 LG	156326	
ASSEMBLY,IDLER SPUR INTERMED	156337	TR-308D
ASSEMBLY,IDLER W/GEAR TRANS	156348	TR-301A-2-SUB
ASSEMBLY,MAIN DRIVE PINION	156513	TR-309A
ASSEMBLY,MAIN DRIVE SHAFT	156524	TR-301R-2-SUB
ASSEMBLY,MOTOR 1/3 HP	156546	PO-306
ASSEMBLY,MOTOR MTG	156568	F-118-SUB
ASSEMBLY,PRI SPRING TRANS ARM	156744	PO-370-1
ASSEMBLY,REAR RLR SHAFT	156788	TR-301A-3-SUB
ASSEMBLY,TENSION ADJ INSERT	157316	PO-188
ASSEMBLY,TRANS HOUSING RH	157470	TR-301R
ASSEMBLY,TRANS LH	157481	TR-301L
ASSEMBLY,TRANS RH	157492	TR-301R-SUB
BAR,PLOW/TANK BRACKET LOCATING	157701	PO-321
BELT,210L100	158878	210L100
BELT,4L370	158658	4L-370
BELT,4L380	158669	4L-380
BELT,4L450	158702	4L-450
BELT,600L100	158889	600L100
BLOCK,CONVEYOR ADJ	159142	F-110B
BRACE,BTM FRONT END PLATE	159923	F-154

<u>Description</u>	<u>New #</u>	<u>Old #</u>
BRACE,CONVEYOR CROSS	159989	F-104A
BRACE,CONVEYOR CROSS SLOTTED1	160000	F-104B
BRACE,CONVEYOR CROSS SLOTTED2	160011	F-104C
BRACE,CONVEYOR CROSS TAPPED	160022	F-104C-2
BRACE,CONVEYOR LEG 1	160044	F-132B
BRACE,GEAR MOTOR MTG	160165	F-118B
BRACKET,ADJ SCREW	160517	PO-315
BRACKET,CONVEYOR BELT IDLER	160825	F-135
BRACKET,IDLER STUD	161210	PO-112
BRACKET,PLOW HOLDDOWN	161639	PL-311
BRACKET,RETURN SPRING TRANS	161694	TR-365
BULB,10-19MA 110V RED	162354	XEL0257L
BUSHING,.19X.38 X.38,ALUMINUM	197334	
BUSHING,FEEDER	162739	F-155
CAPACITOR,8MFD,250V,FEEDER MTR	163399	2A700
CHAIN,LOWER DRIVE	163553	PO-120-1
CHAIN,UPPER DRIVE	163597	PO-122-3
CLAMP,CABLE	163685	3302
CONDUIT,ELBOW	164158	266
CORD,FEEDER MOTOR	164642	FEP-114
CORD,FEEDER POWER	164653	FEP-109
CORD,POWER PLOW	164752	FEP-111
COUPLING,LH THREAD	164356	HMPC-106
COVER,CTN FORWARD BASE	164939	PO-117
COVER,DRIVE SPINDLE CHAIN	165082	PO-113
COVER,FEED ARM TRANS	165225	TR-347
COVER,FEEDER MOTOR	165236	2A701
COVER,TOP TRANS HOUSING	165720	TR-303R
DECAL,TRANS	166435	TR-368
ENCLOSURE,ELECTRICAL	166754	CU-883
FITTING,NIPPLE,CONNECTOR	164389	L-701-1/2
FRAME,CTN FORWARD BASE	167667	PO-114
GEAR,SPUR CASTIRON 48T,16DP,1/2 BORE	196179	
GEAR,SPUR CASTIRON 48T,16DP,5/8 BORE	168624	TR-308D
GEAR,SPUR STEEL 28T,16DP,5/8 BORE	168690	TR-309A

# “A” TYPE POWER OPENER

Product code(s): 19,20

## Master parts list (con't) (Alphabetically by description)

<u>Description</u>	<u>New #</u>	<u>Old #</u>
GEAR,SPUR STEEL 40T,16DP,5/8 BORE	168338	TR-308B
GEAR,SPUR STEEL 40T,16DP,5/8 BORE	168602	TR-308A
GEARBOX,GEAR REDUCER	168756	HMPC-GR1
GUIDE,CARTON FORWARDING	191405	120PO-115
GUIDE,CTN FWD	169614	PO-115
GUIDE,LEFT SIDE CTN	169988	PO-318
GUIDE,LHU FEED END CTN	191416	PO-325L
GUIDE,RHU DICHARGE CTN LEFT	191482	PO-403
GUIDE,RHU DICHARGE CTN RIGHT	191460	PO-402
GUIDE,RHU FEED END CTN	169779	PO-325
GUIDE,RIGHT SIDE CTN	169702	PO-319
HANDLE,ADJ	170285	VO26
HANDLE,KNOB RLR SPINDLE TRANS	170571	TR-366
HINGE,PLOW BRACKET	170780	VO23
KNOB,LEVER ADJ	191471	120PO-391B
LINK,#35 MASTER	171924	HMPC-CL2
MOTOR,1/3HP LEESON	172089	
MOTOR,GEAR 1/20HP	172056	6Z083
MOUNT,GEAR MOTOR	172529	F-118A
MOUNT,MOTOR	172584	PO-306
NUT,HEX NYLOK 8-32	146701	XFY7800C
PAWL,CTN FWD	173387	PO-116
PIN,MICROSWITCH	195277	
PLATE,COVER	174344	PO-312
PLATE,FEEDER CAM BASE	174454	F-153
PLATE,RAIL ADJ	174850	HMPC-57
PLOW,BODY	175378	PL-305
PLOW,BRACKET	175389	PO-307
PLOW,CASTING	175411	PL-349
PLUG,DUMMY FEEDER INLET	175477	FEP-112
PLUG,MALE HUBBELL 7567 C	175587	7567-C
PLUG,MIDGET NEMA ML-1P 15A 125V	175565	7465
PULLEY,3/8PITCH,1WIDE,17GROV ,1/2ID,1.75PD,2.01OD	112370	
PULLEY,GEAR BELT TRANS	176060	TR-364

<b><u>Description</u></b>	<b><u>New #</u></b>	<b><u>Old #</u></b>
PULLEY,MOTOR FAST	176104	AS-20
PULLEY,MOTOR REG	176115	AS-17
RECEPTACLE,BODY NEMA L5-15R15A 125V	176720	4729-C
RECEPTACLE,FLANGEDNEMA ML-1R15A 125V	176489	7468
RECEPTACLE,FLANGED NEMA NOT 10A 250V/15A125V	176511	7557
RETAINER,BELTWAY	177083	F-143
RETAINER,CABLE TIE ANCHOR	148219	XCM0336C
RETAINER,CABLE TIE MEDIUM CLEAR	177105	XCT0104Z
RETAINER,SPRING	177204	PO-327-1
RING,OIL 2 1/8INDIA TRANS	177292	TR-338-2
RING,OIL 2 3/4IN DIA TRANS	177303	TR-338-1
ROD,HEX THREADED	177446	HMPC-105
ROD,THREAD 1/2-13 X 3IN LG 5/32 HOLE	177501	VO25
ROLLER,CORE -141	177655	HMPC-91
SCREW,FRONT RLR SPRING	178513	PO-320-1
SCREW,PRESSURE ADJ REAR RLR	178997	PO-320-2
SEAL,RUBBER CLUTCH TIP TRANS	180229	TR-367
SHAFT,CONVEYOR ELEVATING	180944	F-126
SHAFT,CTN FWD DRIVE	181032	PO-111
SHAFT,DRIVE,ROLLER SPINDLES	197675	TR-301R-3-1
SHAFT,FRONT RLR TRANS	181120	TR-301A-2
SHAFT,MAIN DRIVE TRANS	181428	TR-301R-2
SHAFT,REAR RLR TRANS	181571	TR-301A-3
SHAFT,RLR ARM TRANS	181637	TR-301A-4
SHAFT,RLR SPINDLE DRIVE ASSY	181714	TR-301R-1-SUB
SHAFT,RLR SPINDLE DRIVE TRANS	181725	TR-301R-1
SLEEVE,MEDIUM RUBBER TAN	182264	HMPC-RR1
SLEEVE,POLYURETH,1.25X1.88X.76,ORANGE	195849	XBL0006V
SPACER,LAT	182682	PO-304
SPRING,CTN LOCATING 3 HOLES	153620	
SPRING,PRIMARY TRANS ARM	156744	PO-370-1
SPRING,SECONDARY ADJ KNOB	156964	PO-370-2
SPROCKET,3/8P,13T,1/2 BORE	183804	HMPC-88
SPROCKET,3/8P,18T,1 BORE	184068	PO-122-2

# “A” TYPE POWER OPENER

Product code(s): 19,20

## Master parts list (con't) (Alphabetically by description)

<u>Description</u>	<u>New #</u>	<u>Old #</u>
SPROCKET,3/8P,18T,5/8 BORE	183771	PO-122-1
SPROCKET,3/8P,22T,1/2 BORE	183947	PO-120
SPROCKET,IDLER	183903	PO-221
SPROCKET,RLR SPINDLE TRANS	184013	TR-121
STOP,ELEVATOR ADJ KNOB	184145	F-110D
STUD,IDLER SPROCKET	184475	PO-125
STUD,IDLER TRANS	184486	TR-301A-1
SWITCH,BYPASS FEEDER,1P-2T	193000	2X466(2FC54-73XG)
SWITCH,CONTROL BOX (3WAY)	184783	12TS15-1
SWITCH,LIMIT 20AMP	184871	XBL2051Z
SWITCH,MICRO PLOW ASSY	184970	BZ-2RW-A2
WASHER,FLAT 1/2,BRONZE,SINTERED	187390	F-136B
WASHER,FLAT 3/16X1-1/4X.063ALUMINUM ALLOY	197323	
WHEEL,HAND TRANS	187929	TR-331
WIRE,CONTROL BOX	188237	FEP-113
<b>PRODUCT CODE 20: 120MM ONLY</b>		
ASSEMBLY,BRACKET W/PLOW ASSY	154951	120PO-608
ASSEMBLY,CAM SHAFT	155105	PO-374-120-SUB
ASSEMBLY,CAM SHAFT	155116	PO-375-120-SUB
ASSEMBLY,CORD W/SWITCH	155446	FEP-117
ASSEMBLY,CTN FLAP GUIDE 2/SNSR	155611	120PL-307E
ASSEMBLY,CTN FWD RLR W/RING	155622	PO-404-120-SUB
ASSEMBLY,FEEDER	155908	F- 157
ASSEMBLY,HINGE 4181-NRP-26D	156260	120PO-602
ASSEMBLY,LEVER,CTN HEIGHT ADJ	171583	PO-391-120
ASSEMBLY,MICRO SWITCH	156535	120PO-605
ASSEMBLY,PLOW	156667	120PL-349A-SUB
ASSEMBLY,PLOW BRACKET	156700	120PO-607
ASSEMBLY,TRANS LH, 120MM	199677	
ASSEMBLY,TRANS RH, 120MM	199688	
BEARING,BALL .50 X1.13 X .38 2 SHEILDS	152047	
BELT,600L100	158889	600L100
BLOCK,EXTENSION PLOW ADJ SCREW	159197	PO-393-120
BLOCK,EXTENSION TORQUE LIMITER	159208	PO-394-120

<u>Description</u>	<u>New #</u>	<u>Old #</u>
BLOCK,NYLON CHAIN TENSIONER	159582	PO-385-120
BRACE,ADJ CHUTE BASE	159901	PO-381-120
BRACE,ANLE CHAIN TENSIONER	159912	PO-388-120
BRACE,CONVEYOR LEG 2	160055	F-132B-120
BRACKET,LOWER	161254	120PO-502
BRACKET,UPPER	162024	120PO-501
BUSHING,BRASS CAM SHAFT	162695	PO-390-120
BUSHING,LATCH PLOW BRACKET	162937	120PL-307K
CAM,ADJ CHUTE 1IN	163157	PO-377-120
CAM,ADJ CHUTE 3/8IN	163168	PO-378-120
CAM,INDEX CTN HEIGHT DISC	163267	PO-392-120
CAM,KNURLED PLOW ADJ BRACKET	163278	PO-395-120
CHAIN,TENSIONER CHUTE LEFT	163575	PO-412-120
CHAIN,TENSIONER CHUTE RIGHT	163586	PO-412-120
COVER,CHAIN	164961	PO-389-120
COVER,MICROSWITCH	165764	
COVER,RH FRONT TORQUE LIMITER	165555	PO-409-120
COVER,SENSING HEAD	165577	120PL-349B
COVER,TERMINAL STRIP	165654	PO-407-120
FASTENER,LATCH PLOW BRACKET	166974	120PL-307J
FRAME,LEFT CONVEYOR SIDE	167810	F-101-120
FRAME,LEFT SIDE BOTH FEEDS	167854	PO-371-120
FRAME,RIGHT CONVEYOR SIDE	168019	F-102-120
FRAME,RIGHT SIDE RH UNIT	168074	PO-370-120
GEAR,BEVEL STEEL 20T,16DP,7/6 BORE	168382	F-145
GUARD,CHAIN	197345	NONE
GUIDE,ADJ CHUTE LEVEL	169284	PO-382-120
GUIDE,CONVEYOR BELT 1	169449	F-109A
GUIDE,CONVEYOR BELT 2, TEFLON	169460	F-109B
GUIDE,CONVEYOR CTN	169482	F-107
GUIDE,CTN FLAP	169570	120PL-307G
GUIDE,FEEDER BELT	169790	F-156
GUIDE,LEFT SIDE CTN	170120	120PO-401
GUIDE,LH CONVEYOR CTN	195838	F-107L
GUIDE,LHU FEED END CTN	169592	PO-399-120L

# “A” TYPE POWER OPENER

Product code(s): 19,20

## Master parts list (con't) (Alphabetically by description)

<u>Description</u>	<u>New #</u>	<u>Old #</u>
GUIDE,LHU LEFT SIDE CHUTE	170010	PO-400-120
GUIDE,RHU DICHARGE CTN LEFT	170098	PO-403-120
GUIDE,RHU DICHARGE CTN RIGHT	170109	PO-402-120
GUIDE,RHU FEED END CTN	108047	PO-399-120R
GUIDE,RIGHT SIDE CTN	189689	120PO-400
HANDLE,BRACKET	170296	120PL-307D
HANDLE,KNOB PLOW BRACKET	170549	120PL-307L
HANDLE,KNOB ROUND 6048K31	170582	120PO-604
LEG,CONVEYOR FRAME	171341	F-132A-120
LEVER,SWITCH	171792	VO29
MOTOR,GEAR 1/20HP	172056	6Z083
MOUNT,CAM SLIDER DISCHARGE END	172386	PO-380-120
MOUNT,SHAFT	172694	120PO-507
MOUNT,SPINDLE BEARING	172705	F-108
PIN,HINGE	173618	120PL-307B
PLATE,BAR BACKING	174113	120PO-506
PLATE,CONVEYOR CENTER TOP	174300	F-105B-120
PLATE,CONVEYOR REAR TOP	174333	F-105C-120
PLATE,FEEDER FRONT END	174476	F-152-120
PLATE,FRONT TOP CONVEYOR	174608	F-105A-120
PLATE,LEFT BASE ADJ CHUTE	174652	PO-383-120L
PLATE,RIGHT BASE ADJ CHUTE	175037	PO-383-120R
PLATE, TOP CTN FLAP GUIDE	175257	120PL-307F
PLOW, FLAP OPENING	175345	VO28
PLOW,CASTING	175400	120PL-349A
PULLEY,CONVEYOR BELT DRIVE	175950	F-119
PULLEY,CONVEYOR BELT DRIVEN	175961	F-119A
PULLEY,CONVEYOR BELT IDLER	189645	F-137
RAIL,CTN HEIGHT ADJ	176291	PO-379-120
RECEPTACLE,2 PRONG NEMA ML215A 125V	147427	NONE
ROD,THREADED 3-3/8INLG	177534	120PO-505
ROLLER,CTN FWD MODIFIED	177611	PO-404-120
SCREW,FKHM 8-32 X 3/8	178425	SM-248
SCREW,SHC 1/4-20 X 1-1/4	103636	XFC1612C
SHAFT,ADJ CHUTE CAM	180603	PO-376-120

<b><u>Description</u></b>	<b><u>New #</u></b>	<b><u>Old #</u></b>
SHAFT,ADJ CHUTE CAM 10-3/4 LG	180614	PO-374-120
SHAFT,ADJ CHUTE CAM 10-7/8 LG	180625	PO-375-120
SHAFT,CONVEYOR BELT IDLER	180900	F-136A
SHAFT,CONVEYOR DRIVE	180911	F-125
SHAFT,GUIDE 2-7/8INLG	181164	120PO-504
SHAFT,LATCH PLOW BRACKET	181307	120PL-307H
SHAFT,SWITCH LEVER	181813	120PL-358
SHAFT,TORQUE LIMITER	101348	
SHAFT,TORQUE LIMITER	181890	PO-408-120
SPACER,GUARD,CHAIN	197356	NONE
SPACER,SIDE FRAME SLOTTED	182814	PO-373-120
SPACER,SIDE FRAME UNSLOTTED	182836	120PO-372
SPACER,TORQUE LIMITER SHAFT	182869	PO-410-120
SPRING, PLOW ADJUSTING	182946	120PO-603
SPRING,CHUTE ADJ	183100	PO-13
SPROCKET,ADJ CHUTE CHAIN	183760	PO-384-120
STOP,HING PLOW BRACKET	184178	120PL-307C
SWITCH,MICRO	184937	120PO-600
TORQUE LIMITER	157426	PO-146
WASHER,SPACER	187720	F-127