



MEYERCORD



“A” Type Hot Melt Power Closer
Parts Manual (#201393, v2.0)



Information, Orders, & Technical Support: 1-800-639-3799

This documentation is protected by United States copyright laws. Copyright 2001 by The Meyercord Company. All rights reserved. Reproduction of material is strictly prohibited without written permission. The Meyercord Company, 365 E. North Avenue, Carol Stream, IL. 60188. Printed in the United States.

Table of Contents

How to use this manual	2
Fig. 1	
Glue pot assembly	6
Fig. 2	
Top, external	8
Fig. 3	
Top, internal	10
Fig. 4	
Right side	12
Fig. 5	
Right side - Decals	14
Fig. 6	
Bottom, internal	16
Master parts list	18

“A” TYPE HOT MELT POWER CLOSER

Product code: 30

How to use this manual

1. All components pictured are from an **Adco 120mm Hot Melt Power Closer (RHU)**. Keep in mind that the pictures are provided as general visual guides. Locating the right part number is as easy as locating the part on the picture and finding its identifying number on the facing parts list. The list will then provide the six digit part number.
2. In order better understand the sections and part descriptions, take a look at the following definitions:



The arrow is used to imply the general location of a part that is partially hidden or too small to be seen easily with a normal line.

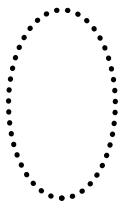

The dotted circle is there to bring your attention to a specified area, and can have two meanings:

- (1) It highlights a group of parts in a small area.
- (2) It represents the location of a part that cannot be seen or is not pictured at all.

3. Using the picture on the facing page, look for **2d**. Notice that it says '*not shown*'. Throughout this manual, some parts or locations are implied. Although they may not be easy to see or are not pictured, they are identified. Look for a number pointing to the part or parts general location, or a combination of numbers that point at one location (i.e. **2a-2d**).
4. You may notice that hardware is occasionally shown with a part number. This is only for special components for which the performance of the machine is dependent on the correct part. All other hardware needs can be purchased at a local hardware store or vendor. The six digit part number is provided so that if there is a question about any dimension, it can be easily located in the parts list. Quantities are provided at the end of the description.

5. You will notice that on a few occasions, letters are added to the numbers. These parts complement each other, or work together in a mini-assembly, and are grouped together, even though they are physically different. As shown in this example, while **2a-2d** are different parts, their relation to each other is close enough to group them together on the list.

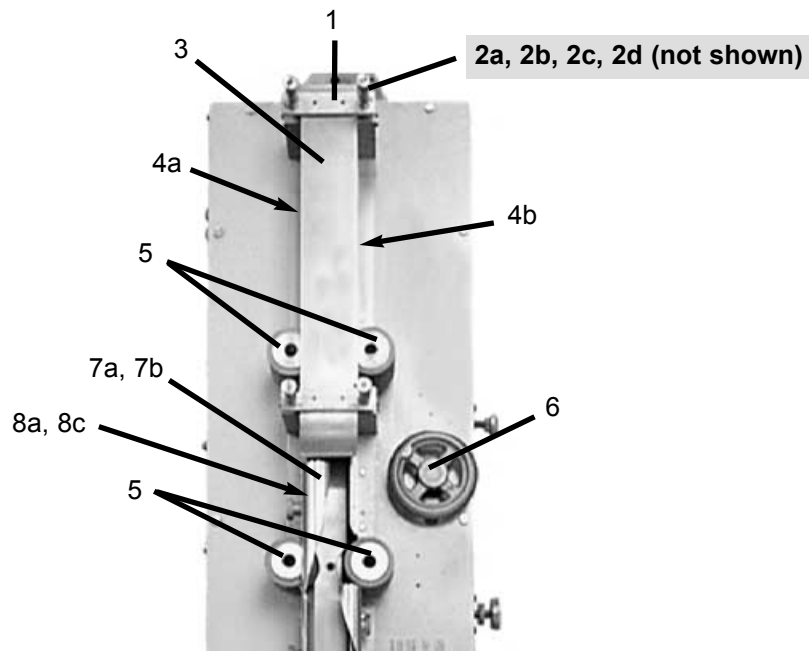

1. 161177	BRACKET,HOLDDOWN COVER
2a. 165610	COVER,SPRING RETAINER
2b. 191097	SPRING,COMP 1/2 X X 4-1/2
2c. 181208	SHAFT,HOLD DOWN
2d. 198236	WASHER, FELT .25 X .63 X 1/16
3. 165313	COVER,HOLDDOWN
4a. 169372	GUIDE,CTN #7, HOLDDOWN LEFT SIDE
4b. 169383	GUIDE,CTN #8, HOLDDOWN RIGHT SIDE
5. <u>199039</u>	ROLLER,CARTON FORWARDING
6. 156161	ASSEMBLY,HAND WHEEL
7a. 167436	FLAP,FOLDER LEFT SIDE, RHU
7b. 191240	FLAP,FOLDER LEFT SIDE, LHU
8a. 169350	GUIDE,CTN #5
8b. 169361	GUIDE,CTN #6
8c. 191207	GUIDE,CARTON,#5,LH-PB
8d. 191218	GUIDE,CARTON,#6,LH-PB

“A” TYPE HOT MELT POWER CLOSER

Product code: 30

How to use this manual (cont'd)

6. In order to better understand some of the parts listed (as well as the following examples), look at the following definitions:

Left Hand Unit (LHU, or LH): cigarette cartons moving from right to left

Right Hand Unit (RHU, or RH): cigarette cartons moving from left to right

(Determined by standing on the operators side facing the machine)

Parts orientation

(Determined by facing the machine in the direction the cartons move)

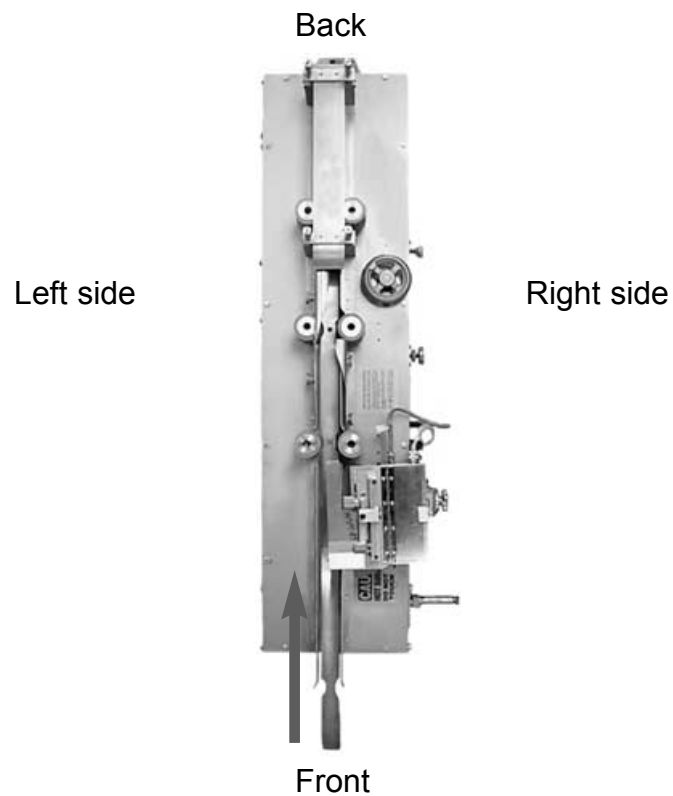

7. Sometimes two parts serve the same function in the same location, and their only difference is that one is for a left hand unit (LHU), and the other is for a right hand unit (RHU).

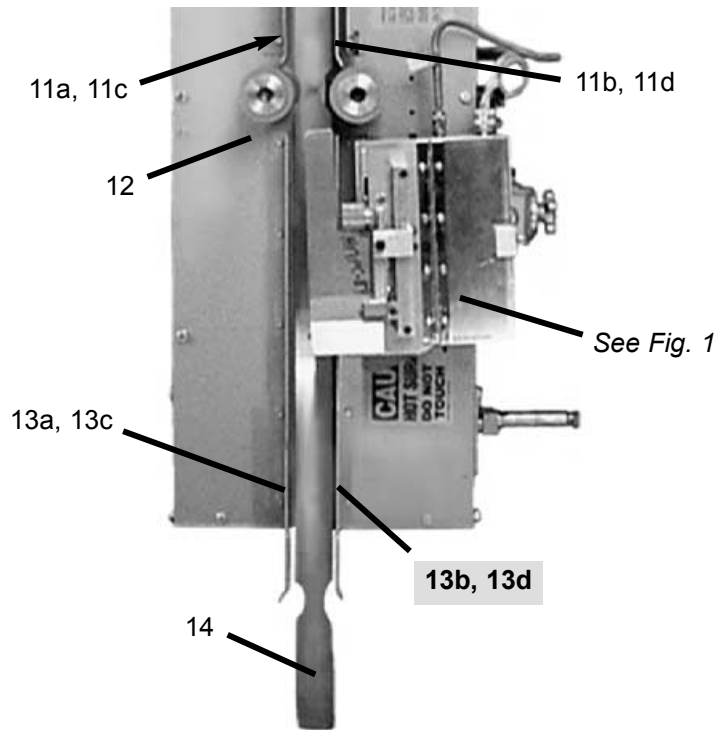

11a. 169328	GUIDE,CTN #3
11b. 169339	GUIDE,CTN #4
11c. 191339	GUIDE,CARTON,#3,LH-PB
11d. 191350	GUIDE,CARTON,#4,LH-PB
12. 177666	ROLLER,CORE 141 #1
13a. 169306	GUIDE,CTN #1 CD
13b. 169317	GUIDE,CTN #2 CD
13c. 191284	GUIDE,CARTON,#1,LH-PB
13d. 191328	GUIDE,CARTON,#2,LH-PB
14. 176324	RAIL,LG CTN ADJ

This example indicates that either **13b** or **13d** can be used as the carton guide under the glue pot, depending on whether the machine is a LHU or a RHU.

“A” TYPE HOT MELT POWER CLOSER

Product code: 30

Figure 1 - Glue pot assembly

FULL ASSEMBLY

	111787	ASSEMBLY,POT,GLUE,HOT MELT
1.	161738	BRACKET,RLR PIVOT ARM MTG
2.	178887	BRACKET,ADJ SCREW
3a.	181703	SHAFT,RLR LEVER
3b.	151167	RING,RETAINER,E,3/16
4.	184035	LEVER,RLR W/ BUSHING
5.	106507	RETAINER,SPRING
6.	183045	SPRING,COMP .25 X .03 X .63
7a.	181615	SHAFT,RLR
7b.	151167	RING,RETAINER,E,3/16
8.	177776	ASSEMBLY,GLUE POT ROLLER
9.	169405	GUIDE,CTN FLAP-EXTENDED
10a.	188017	WIPER,GLUE WHEEL
10b.	174102	PLATE,BACKING
11.	165390	COVER,HOT MELT POT
12.	165291	COVER,GLUE POT
13.	170450	HANDLE,KNOB GLUE POT
14a.	187874	WHEEL,GLUE POT
14b.	162893	BUSHING,GLUE POT WHEEL
15.	180405	SENSOR,TEMP
16.	175565	PLUG,MIDGET NEMA ML-1P 15A 125V

Fig. 1

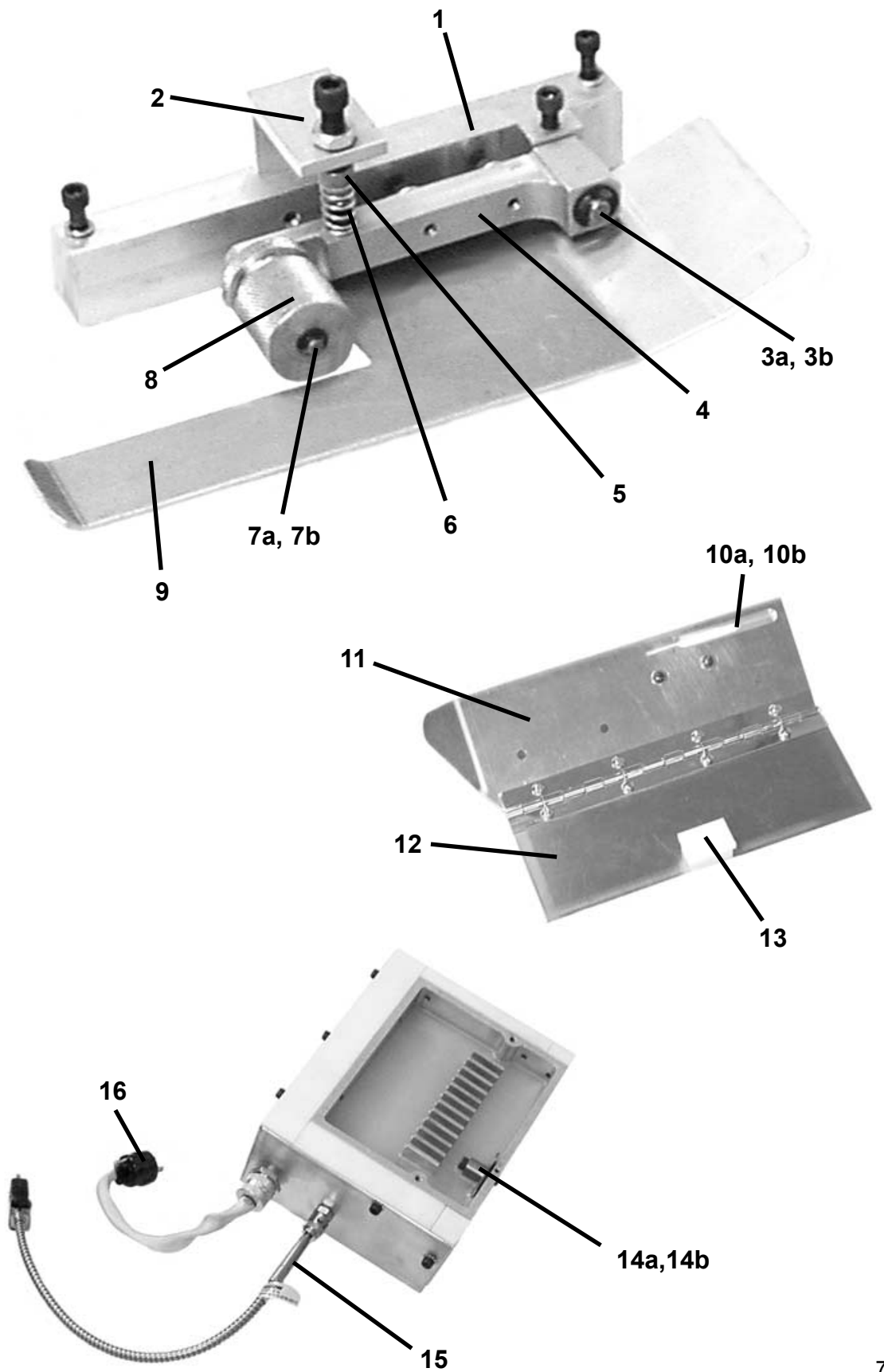

“A” TYPE HOT MELT POWER CLOSER

Product code: 30

Figure 2 - Top, external

1.	161177	BRACKET,HOLDDOWN COVER
2a.	165610	COVER,SPRING RETAINER
2b.	191097	SPRING,COMP 1/2 X X 4-1/2
2c.	181208	SHAFT,HOLD DOWN
2d.	198236	WASHER, FELT .25 X .63 X 1/16
3.	165313	COVER,HOLDDOWN
4a.	169372	GUIDE,CTN #7, HOLDDOWN LEFT SIDE
4b.	169383 *	GUIDE,CTN #8, HOLDDOWN RIGHT SIDE
<u>100mm/120mm</u>		
5.	199039	ROLLER,CARTON FORWARDING
6.	156161	ASSEMBLY,HAND WHEEL
7a.	167436	FLAP,FOLDER LEFT SIDE, RHU
7b.	191240	FLAP,FOLDER LEFT SIDE, LHU
8a.	169350	GUIDE,CTN #5
8b.	169361	GUIDE,CTN #6
8c.	191207	GUIDE,CARTON,#5,LH-PB
8d.	191218	GUIDE,CARTON,#6,LH-PB
9a.	167447	FLAP,FOLDER RIGHT SIDE, RHU
9b.	154269	FLAP,FOLDER RIGHT SIDE, LHU
10a.	169328	GUIDE,CTN #3
10b.	169339	GUIDE,CTN #4
10c.	191339	GUIDE,CARTON,#3,LH-PB
10d.	191350	GUIDE,CARTON,#4,LH-PB
<u>100mm/120mm</u>		
11.	177666	ROLLER,CORE 141 #1
12a.	169306	GUIDE,CTN #1 CD
12b.	169317	GUIDE,CTN #2 CD
12c.	191284	GUIDE,CARTON,#1,LH-PB
12d.	191328	GUIDE,CARTON,#2,LH-PB
13.	176324	RAIL,LG CTN ADJ
14.	195684	DECAL,OPERATOR ROLLER BRACKET
15.	195695	DECAL,CAUTION HOT
16.	111787	ASSEMBLY,POT,GLUE,HOT MELT

**MUST BE ORDERED WITH 166160 (DECAL- #13 ON PAGE 14)*

Fig. 2

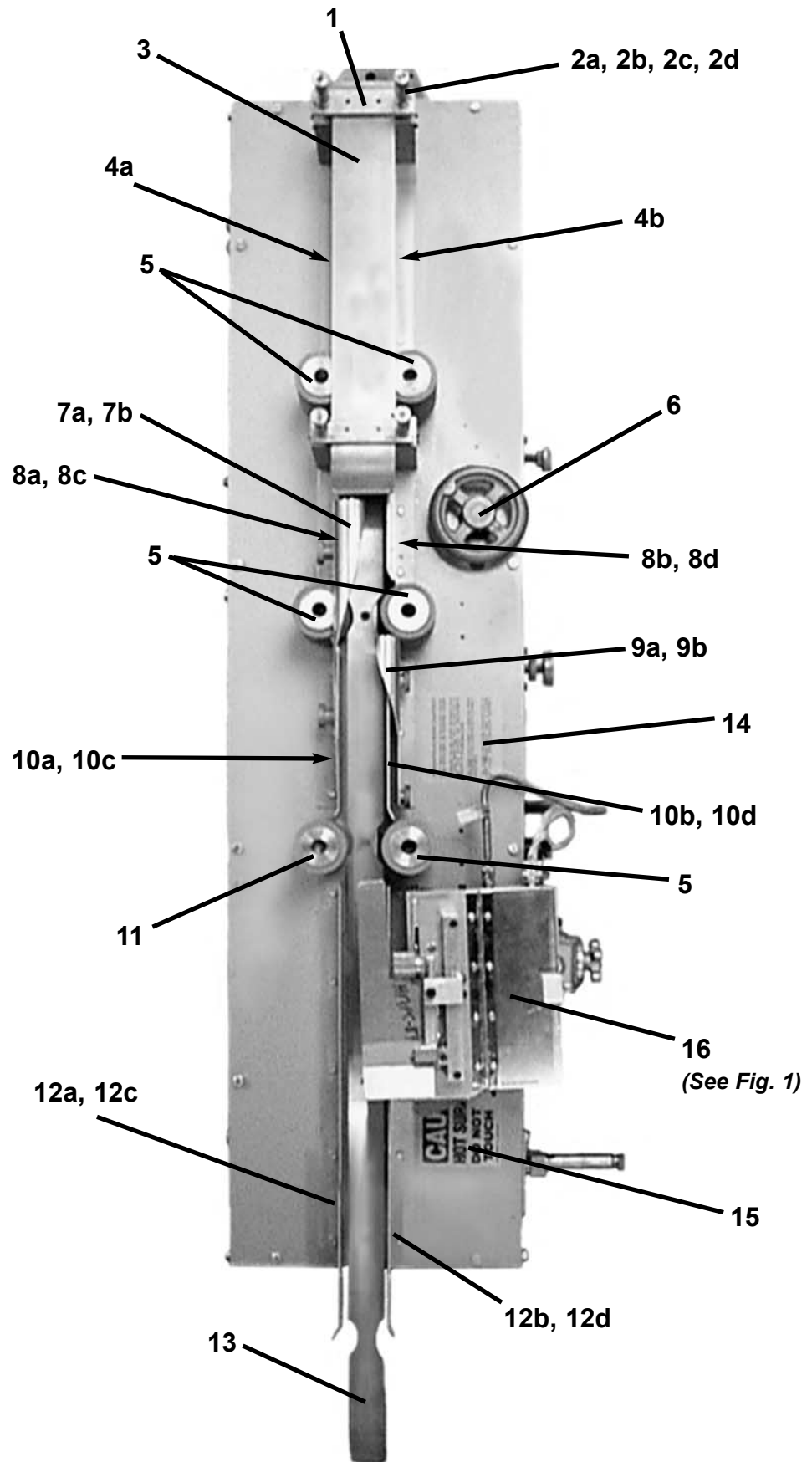

“A” TYPE HOT MELT POWER CLOSER

Product code: 30

Figure 3 - Top, internal

1.	163300	CAM,LOBE
1a.	181505	SHAFT,RAIL ADJ ARM
1b.	181494	SHAFT,RAIL ADJ
1c.	162695	BUSHING,BRASS CAM SHAFT
2.	183760	SPROCKET,ADJ CHUTE CHAIN
3a.	177446	ROD,HEX THREADED
3b.	164356	COUPLING,LH THREAD
4a.	107750	ASSEMBLY,AUX REAR RLR BRACKET
4b.	176225	RAIL,141 MTG
5.	163465	CHAIN,#25 RAIL ADJ
6a.	158977	BLOCK,ATTACHING 141 ADJ SCREW
6b.	180680	SHAFT,ADJ-141
7a.	107673	COUPLING,SHAFT MALE
7b.	164312	COUPLING,FEMALE 141 SHAFT
8a.	194232	ASSEMBLY,BRACKET,RLR,STA FRONT
8b.	183672	SPROCKET,3/8P,11T,3/8 BORE
9.	163487	CHAIN,#35 DRIVE
10a.	160517	BRACKET,ADJ SCREW
10b.	157316	ASSEMBLY,TENSION ADJ

Fig. 3

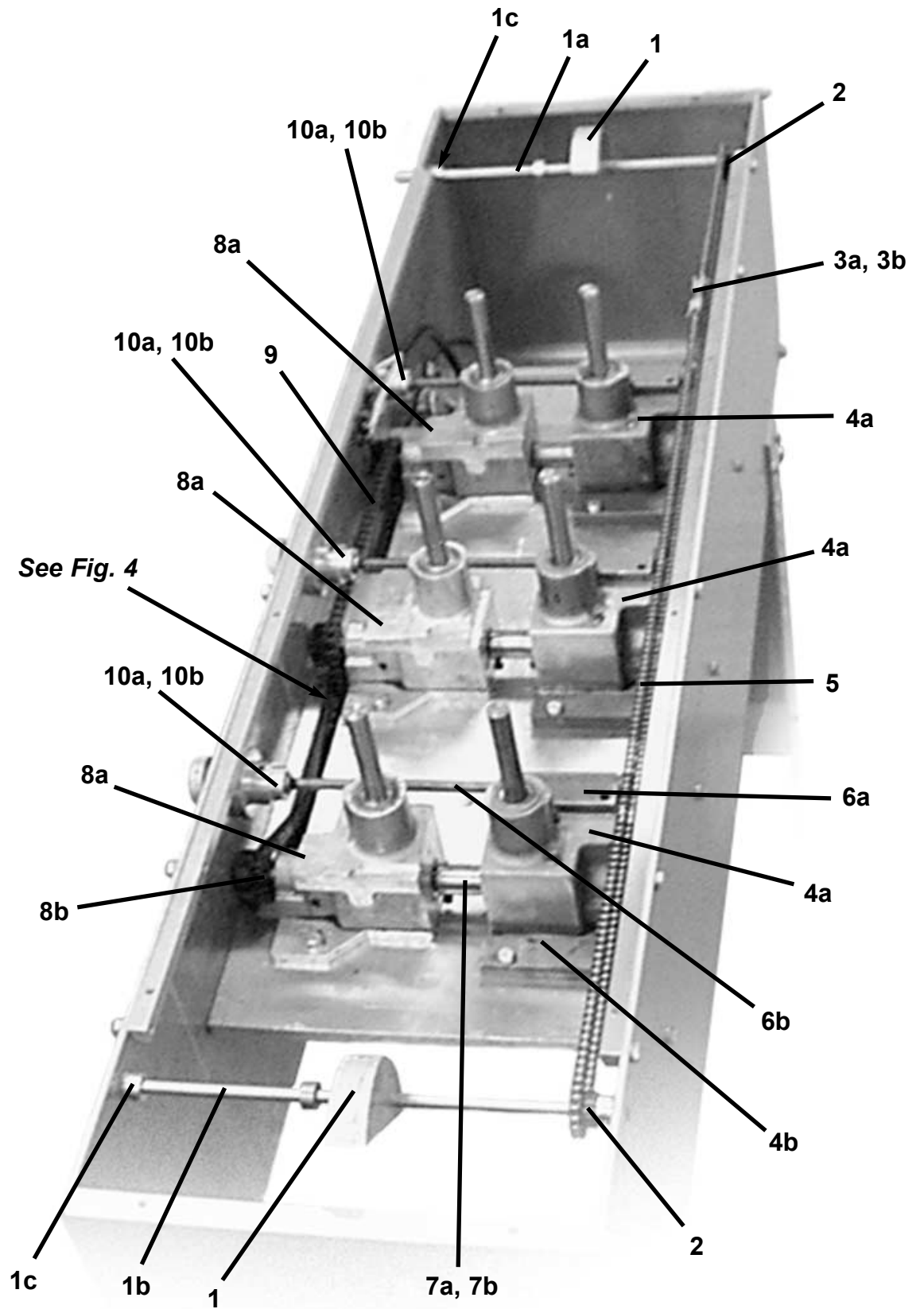

“A” TYPE HOT MELT POWER CLOSER

Product code: 30

Figure 4 - Right side

1.	113602	ASSEMBLY,HANDLE CHUTE ELEVATING
2.	174850	PLATE,RAIL ADJ
3.	182297	SLEEVE,RUBBER
4.	170428	HANDLE,KNOB CLOSING FLAP ADJ
5a.	161892	BRACKET,TAKE UP
5b.	181857	SHAFT,TAKE-UP
5c.	184057	SPROCKET,3/8P,16T,1-1/8 BORE
6.	170373	HANDLE,KNOB ADJ-141
7.	166820	ENCLOSURE, NEMA 4 INCLINE
8.	176489	RECEPTACLE,FLANGED NEMA ML-1R 15A 125V
9.	176775	REGULATOR,TEMP
10.	162277	BREAKER,7.5A
11a.	104571	PLUG,INLET,NEMA L5-15,15A/125V
11b.	104582	RECEPTACLE,NEMA L5-15R
11c.	149902	WIRE,16AWG/3C BLK SJOW
12a.	157701	BAR,PLOW/TANK BRACKET LOCATING
12b.	159384	BLOCK,MTG
13.	187687	WASHER,PLOW BRACKET
14.	170472	HANDLE,KNOB GLUE POT BRKT LOCK
15.	161100	BRACKET,GLUE POT MTG
16.	187698	WASHER,POT BRACKET LOCK
17.	111787	ASSEMBLY,POT,GLUE,HOT MELT
18.	168965	GUARD,ELECTRICAL ENCLOSURE

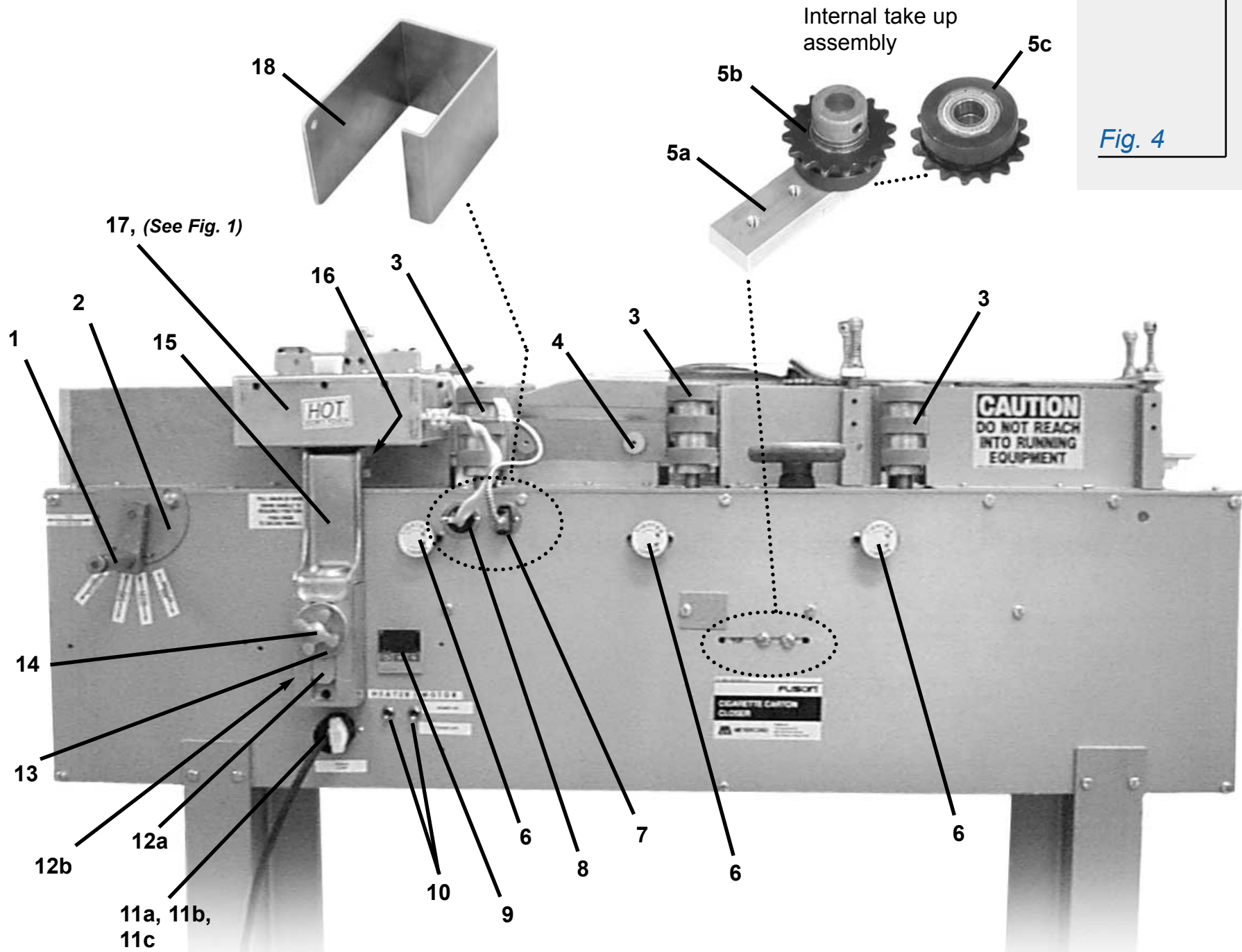

Fig. 4

“A” TYPE HOT MELT POWER CLOSER

Product code: 30

Figure 5 - Right side - Decals

- | | | |
|-----|---------------|------------------------------------|
| 1. | 109081 | DECAL,ELEVATING HANDLE,120 MM |
| 2. | 109059 | DECAL,ELEVATING HANDLE,100 MM |
| 3. | 109092 | DECAL,ELEVATING HANDLE,KING SIZE |
| 4. | 109103 | DECAL,ELEVATING HANDLE,CRUSH PROOF |
| 5. | 109114 | DECAL,ELEVATING HANDLE,REG SIZE |
| 6. | 195563 | DECAL.POWER CORD |
| 7. | 109180 | DECAL,HEATER |
| 8. | 109191 | DECAL,MOTOR |
| 9. | 106815 | DECAL,ON |
| 10. | 106804 | DECAL,OFF |
| 11. | 109224 | DECAL,ADJ CTN FWD RLR |
| 12. | 166127 | DECAL,CTN CLOSER NAMEPLATE |
| 13. | 166160 | DECAL,DANGER HANDS AND FINGERS |
| 14. | 195695 | DECAL,CAUTION HOT |

Fig. 5

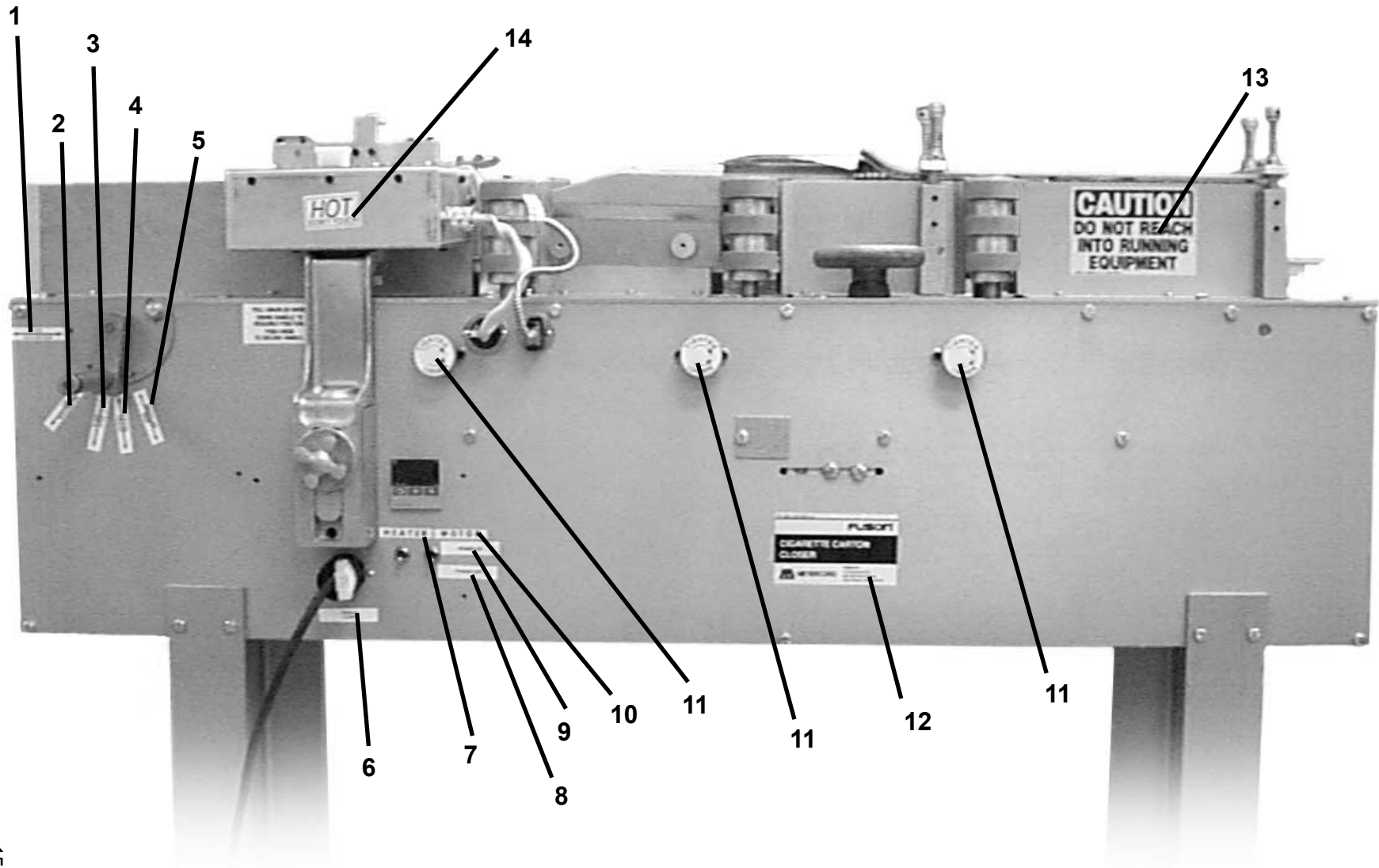

“A” TYPE HOT MELT POWER CLOSER

Product code: 30

Figure 6 - Bottom, internal

1.	176775	REGULATOR,TEMP
2.	183375	SPRING,RELAY HOLDDOWN
3.	193066	RELAY,ICE CUBE
4.	176797	BLOCK,MODU
5.	104571	PLUG,INLET,NEMA L5-15,15A/125V
6.	162277	BREAKER,7.5A
7.	172089	MOTOR,1/3HP LEESON
7a.	112392	GEARBOX
7b.	112425	MOUNT,GEAR REDUCER
8.	183804	SPROCKET,3/8P,13T,1/2 BORE

Fig. 6

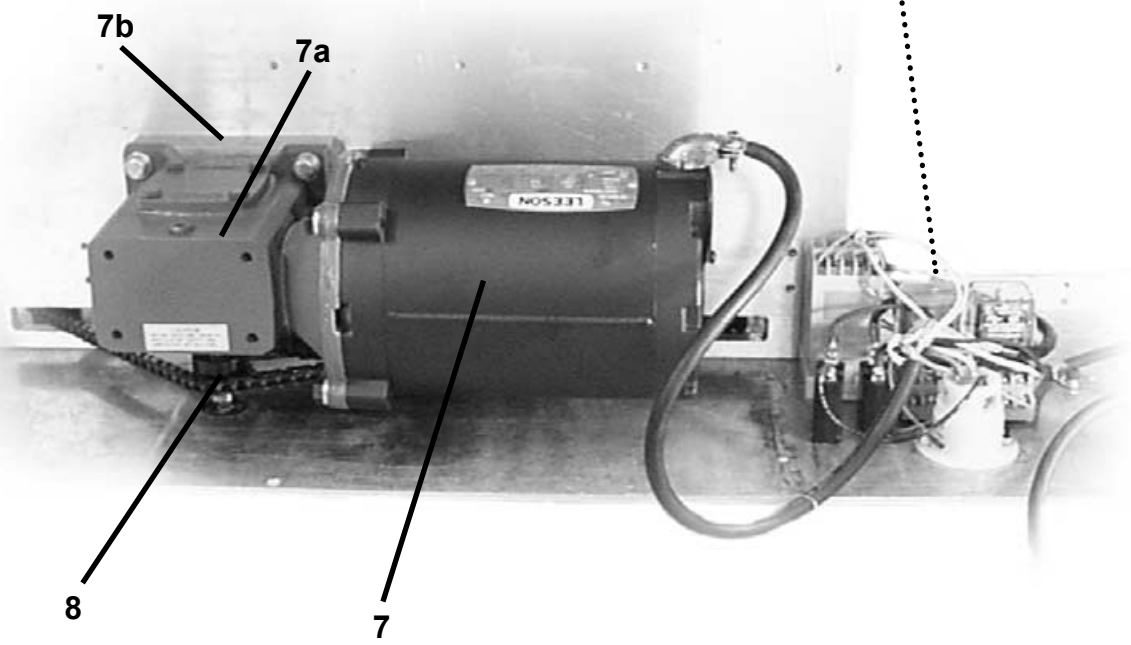
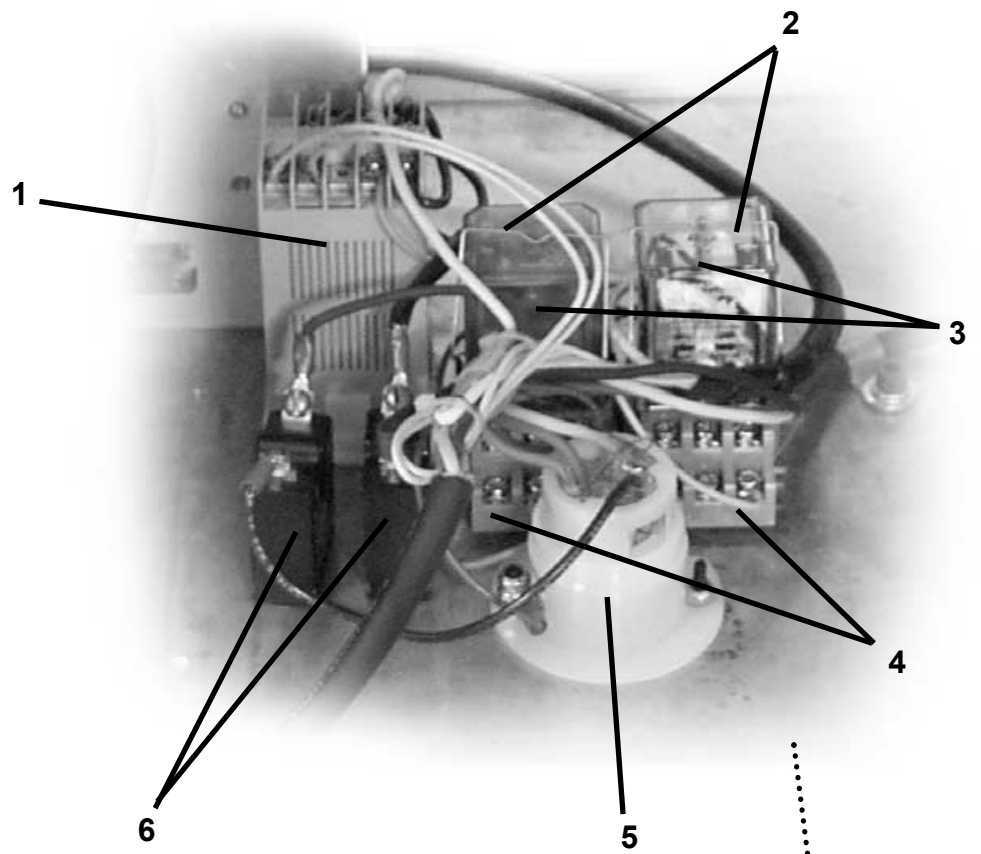

“A” TYPE HOT MELT POWER CLOSER

Product code: 30

Master parts list (Alphabetically by description)

<u>Description</u>	<u>New #</u>	<u>Old #</u>
ASSEMBLY,AUX REAR RLR BRACKET	107750	
ASSEMBLY,BRACKET,RLR,STA FRONT	194232	
ASSEMBLY,GLUE POT ROLLER	177776	GT-251- 1 (HMPC-89)
ASSEMBLY,GUIDE,CARTON,# 2	191317	HMPC- 16B-SUB
ASSEMBLY,HAND WHEEL	156161	HMPC- 139
ASSEMBLY,HANDLE CHUTE ELEVATING	113602	SM-147-SUB
ASSEMBLY,HEIGHT KNOB ADJ	156249	HMPC- 137
ASSEMBLY,POT,GLUE,HOT MELT	111787	
ASSEMBLY,SPROCKET,3/8P,24T,1/2 BORE	183518	P-56
ASSEMBLY,TENSION ADJ	157316	PO-188
ASSEMBLY,UPPER ARM/RLR MOUNT	196003	
BAFFLE,HOT MELT	190426	HMPC-42
BAR,PLOW/TANK BRACKET LOCATING	157701	PO-321
BASE,RELAY-11 PIN 1	157954	HMPC-RB1
BASE,RELAY-11 PIN 2	157965	HMPC-RB2
BEARING,1/2INRLR BRACKET	158119	SR6-5PP
BEARING,BUSH,FLANGED	162860	HMPC-92
BLOCK,ATTACHING 141 ADJ SCREW	158977	HMPC-54
BLOCK,GEARBOX MTG	191988	
BLOCK,GLUE POT INSULATION,LEFT	191119	HMPC-07L
BLOCK,HOLDDOWN BRACE	159263	HMPC-33
BLOCK,MODU	176797	M4BF1
BLOCK,MTG	159384	HMPC-53
BLOCK,RUBBER,HAND-WHEEL	196267	
BLOCK,WITH HOLES	191053	HMPC-43
BLOCK,WITH HOLES	191064	HMPC-43L
BOX,GLUE CHIPS	168778	HMPC-123
BRACE,TOP	160440	HMPC-118
BRACKET,ADJ SCREW	178887	HMPC-82
BRACKET,ADJ SCREW	160517	PO-315
BRACKET,ATTACHING-PACKER	160583	HMPC-96
BRACKET,BTM MTG	160671	HMPC-30
BRACKET,CHUTE SPIRAL ASSY	160814	HMPC-112
BRACKET,CTN FORWARD RLR	160726	HMPC-113
BRACKET,CTN STABILIZER	105429	

<u>Description</u>	<u>New #</u>	<u>Old #</u>
BRACKET, GLUE POT MTG	161100	HMPC-40
BRACKET, HOLDDOWN COVER	161177	HMPC-34
BRACKET, L	191086	HMPC-45
BRACKET, RLR PIVOT ARM MTG	161738	HMPC-81
BRACKET, STAMPER MTG	161826	HMPC-73
BRACKET, TAKE UP	161892	HMPC-26
BRACKET, TOP MTG	161969	HMPC-31
BRACKET, TRIANGLE PACKER MTG	161980	HMPC-122
BRACKET, Z	191075	HMPC-44
BREAKER, 20A	162266	HMPC-CB1
BREAKER, 7.5A	162277	HMPC-CB2
BUSHING, BRASS CAM SHAFT	162695	PO-390-120
BUSHING, GLUE POT WHEEL	162893	HMPC-70
BUSHING, GUIDE	162926	HMPC-41
BUSHING, LEVELING JACK	190415	NONE
BUSHING, THREADED	147361	
CAM, LOBE	163300	HMPC-49
CHAIN, #25 RAIL ADJ	163465	HMPC-108
CHAIN, #35 DRIVE	163487	HMPC-109
CLIP, HEATER RETAINER	163861	HMPC-19
CLOSER, CARTON, LEFT, LH-PB	191240	HMPC-14L
COLLAR, FLANGED SHAFT	191031	HMPC-80
COLLAR, SHAFT, END	191196	HMPC-59
CONNECTOR, CORD, MALE, STRAIT, RED, ALUMINUM	195145	
CONTROLLER, TEMPERATURE	166655	E5-CS-R1KJX-F
CORD, POWER SERVICE	164763	HMPC-PC
COUPLING, FEMALE 141 SHAFT	164312	HMPC-116 / RB-141-L3
COUPLING, LH THREAD	164356	HMPC-106
COUPLING, MALE 141 SHAFT	164378	HMPC-129
COUPLING, RH THREAD	164455	HMPC-107
COUPLING, FEMALE 141 SHAFT	164312	HMPC-116 / RB-141-L3
COUPLING, SHAFT MALE	107673	RB-141L-1
COVER, 1/4IN SPIRAL WRAP WIRE	164840	HMPC-133
COVER, ELECTRICAL	165159	HMPC-94
COVER, ELECTRICAL END CAP	165192	HMPC-95

“A” TYPE HOT MELT POWER CLOSER

Product code: 30

Master parts list (cont'd) (Alphabetically by description)

<u>Description</u>	<u>New #</u>	<u>Old #</u>
COVER, GLUE POT	165291	HMPC-47
COVER, HOLDDOWN	165313	HMPC-35
COVER, HOT MELT POT	165390	HMPC-04
COVER, POT OUTER, LEFT	194859	HMPC-05L
COVER, POT OUTER, RIGHT	165511	HMPC-05
COVER, SPRING RETAINER	165610	HMPC-56
DECAL, ADJ CTN FWD RLR	109224	DD53
DECAL, CAUTION HOT	195695	146
DECAL, CTN CLOSER NAMEPLATE	166127	146
DECAL, DANGER HANDS AND FINGERS	166160	DD39
DECAL, ELEVATING HANDLE, 100 MM	109059	DD53
DECAL, ELEVATING HANDLE, 120 MM	109081	146
DECAL, ELEVATING HANDLE, CRUSH PROOF	109103	146
DECAL, ELEVATING HANDLE, KING SIZE	109092	
DECAL, ELEVATING HANDLE, REG SIZE	109114	146
DECAL, HEATER	109180	DD52
DECAL, MOTOR	109191	
DECAL, OFF	106804	DD10
DECAL, ON	106815	DD52
DECAL, OPERATOR ROLLER BRACKET ..	195684	
DECAL, POWER CORD	195563	
DOCUMENT, SCHEMATIC, ELECTRICAL ,POWER	196399	
ELEMENT, HEATER 650W 6IN LG	166644	HMPC-H1
ENCLOSURE, GLUE CHIP	150496	
FITTING, THREADED INSERT-141	167403	HMPC-23
FLAP, FOLDER LEFT SIDE, LHU	191240	HMPC-14L
FLAP, FOLDER LEFT SIDE, RHU	167436	HMPC-14
FLAP, FOLDER RIGHT SIDE, LHU	154269	HMPC-13L
FLAP, FOLDER RIGHT SIDE, RHU	167447	HMPC-13
GEAR, BEVEL STEEL 16T, 16DP, 3/8 BORE	168360	RB-165A-2
GEAR, BEVEL STEEL 16T, 16DP, 3/8 BORE	168404	RB-165A
GEAR, BEVEL STEEL 24T, 16DP, 1/2 BORE	168327	HMPC-117
GEAR, BEVEL STEEL 24T, 16DP, 3/8 BORE	168349	RB-165
GEAR, SPUR STEEL 20T, 12DP, 5/8 BORE	168547	NSS-1220
GEARBOX	112392	

<u>Description</u>	<u>New #</u>	<u>Old #</u>
GUARD,ELECTRICAL ENCLOSURE	168965	HMPC-76
GUARD,INSTALLATION	169020	HMPC-121
GUIDE,CARTON	191020	HMPC-74
GUIDE,CARTON,#1	191262	HMPC-15A
GUIDE,CARTON,#1,LH-PB	191284	HMPC-15L
GUIDE,CARTON,#2	191306	HMPC-16A
GUIDE,CARTON,#2,LH-PB	191328	HMPC-16L
GUIDE,CARTON,#3,LH-PB	191339	HMPC-17L
GUIDE,CARTON,#4,LH-PB	191350	HMPC-18L
GUIDE,CARTON,#5,LH-PB	191207	HMPC-64L
GUIDE,CARTON,#6,LH-PB	191218	HMPC-65L
GUIDE,CARTON,SM EXIT	191361	HMPC-12A
GUIDE,CTN #1 CD	169306	HMPC-15B
GUIDE,CTN #2 CD	169317	HMPC-16B
GUIDE,CTN #3	169328	HMPC-17
GUIDE,CTN #4	169339	HMPC-18
GUIDE,CTN #5	169350	HMPC-64
GUIDE,CTN #6	169361	HMPC-65
GUIDE,CTN #7, LEFT SIDE HOLDDOWN	169372	HMPC-66
GUIDE,CTN #8, RIGHT SIDE HOLDDOWN	169383	HMPC-67
GUIDE,CTN FLAP-EXTENDED	169405	HMPC-84
GUIDE,CTN STAMP MACHINE	169713	HMPC-12
GUIDE,MINOR FLAP	197180	HMPC-79
GUIDE,TOP FLAP	170252	HMPC-50
HANDLE,KNOB 141 ADJ LOCK	170351	HMPC-102
HANDLE,KNOB ADJ-141	170373	HMPC-100
HANDLE,KNOB CLOSING FLAP ADJ	170428	ACC-113
HANDLE,KNOB GLUE POT	170450	HMPC-46
HANDLE,KNOB GLUE POT ADJ	170461	HMPC-101
HANDLE,KNOB GLUE POT BRKT LOCK	170472	HMPC-103
HANDLE,KNOB HEIGHT ADJ	170505	HMPC-141
HINGE,3/4IN 8IN	170659	HMPC-135
HOLDER,SPRING	170912	HMPC-61
HOUSING,GEARBOX,RLR	107046	TR-148A
HUB,FLANGE,ADJ SCREW	178502	HMPC-138

“A” TYPE HOT MELT POWER CLOSER

Product code: 30

Master parts list (cont'd) (Alphabetically by description)

<u>Description</u>	<u>New #</u>	<u>Old #</u>
INSULATION	170934	HMPC-131
INSULATION,#1	170945	HMPC-06
INSULATION,#12,RIGHT	170956	HMPC-07
INSULATION,#3,LEFT	194870	HMPC-08L
INSULATION,#3,RIGHT	170967	HMPC-08
INSULATION,#4,LEFT	194881	HMPC-09L
INSULATION,#4,RIGHT	170978	HMPC-09
INSULATION,#5,LEFT	194980	HMPC-10L
INSULATION,#5,RIGHT	170989	HMPC-10
INSULATION,#6,LEFT	194991	HMPC-11L
INSULATION,#6,RIGHT	171000	HMPC-11
KIT,CONVERSION,GLUE POT/MOTOR SWITCH	196410	
LEG,LEFT	171407	HMPC-37L
LEG,RIGHT	171451	HMPC-37R
LEG,VERT MTG	171528	HMPC-38
LEG,VERT MTG LG	171539	HMPC-39A
LEVER,RLR	171748	HMPC-83
MOTOR,1/3HP 1725RPM	172100	HMPC-M1
MOTOR,1/3HP LEESON	172089	
MOUNT,GEAR REDUCER	112425	
PANEL,LEFT CTN CLOSER	154269	HMPC-13L
PLATE, TOP, A	108135	HMPC-20A
PLATE, TOP, B	108146	HMPC-20A
PLATE,141 ADJ BASE	174014	HMPC-130
PLATE,BACKING	174102	HMPC-72
PLATE,BASE LG SHORT RH	174190	HMPC-22
PLATE,END	174410	HMPC-29
PLATE,LEFT SIDE LG	174718	HMPC-25A
PLATE,RAIL ADJ	174850	HMPC-57
PLATE,RH SIDE LG	175026	HMPC-24A
PLATE,RLR BRACKET BASE	175081	RB-141F
PLUG,INLET,NEMA L5-15,15A/125V	104571	XCO3157L
PLUG,MIDGET NEMA ML-1P 15A 125V	175565	7465
POT,HOT MELT GLUE,RIGHT	175719	HMPC-03
RAIL,141 MTG	176225	HMPC-110/RB-141-J-1

<u>Description</u>	<u>New #</u>	<u>Old #</u>
RAIL,LG BRACE	176346	HMPC-51A
RAIL,LG CTN ADJ	176324	HMPC-52A
RAIL, TOP BRACE LG	176401	HMPC-32A
RECEPTACLE,FLANGED	176478	HMPC-FR2
RECEPTACLE,FLANGED NEMA ML-1R 15A 125V	176489	7468
RECEPTACLE,FLANGED,NEMA L5-15R 15A/125V	180427	4715
RECEPTACLE,HMPC FLANGED INLET	176577	
RECEPTACLE,NEMA L5-15R	104582	XCP3057Z
RECEPTACLE,TEMP PROBE FLANGED	176709	
REGULATOR,TEMP	176775	HMPC-TC1
RELAY,HEATER CIRCUIT	176973	HMPC-R2
RELAY,ICE CUBE	193066	P-R1-R2
RETAINER,SPRING	106507	
RING,RETAINER,E,3/16	151167	
ROD,HEIGHT ADJ	177435	HMPC-140
ROD,HEX THREADED	177446	HMPC-105
ROLLER,CORE -141	177655	HMPC-91
ROLLER,CORE 141 #1	177666	HMPC-02
ROLLER,CORE, SHORT 3 SLEEVE	177600	RB-143E-120
ROLLER,CTN FWD MODIFIED	177611	PO-404-120
ROLLER,GLUE TANK	190184	
SCREW,ADJ RLR ARM,1/4-20 X 1 ,BRASS	178128	HMPC-62
SENSOR,TEMP	180405	HMPC-TP1
SHAFT,141	180548	HMPC-114
SHAFT,141 RLR	180559	HMPC-120
SHAFT,ADJ COLLAR	180647	HMPC-60
SHAFT,ADJ-141	180680	HMPC-58
SHAFT,GLUE POT WHEEL	181142	HMPC-136
SHAFT,HAND WHEEL	181186	HMPC-48
SHAFT,HOLD DOWN	181208	HMPC-36
SHAFT,RAIL ADJ	181494	HMPC-55
SHAFT,RAIL ADJ ARM	181505	HMPC-75
SHAFT,RLR	181615	HMPC-87
SHAFT,RLR LEVER	181703	HMPC-86
SHAFT,SLOTTED-141	181769	HMPC-21

“A” TYPE HOT MELT POWER CLOSER

Product code: 30

Master parts list (cont'd) (Alphabetically by description)

<u>Description</u>	<u>New #</u>	<u>Old #</u>
SHAFT,TAKE-UP	181857	HMPC-27
SHELL,BACK	183617	97-3057-1007-1
SLEEVE,LOWER BEARING 141	182253	RB-141D
SLEEVE,MEDIUM RUBBER	182264	HMPC-RR1
SLEEVE,RUBBER	182297	HMPC-RR
SLEEVE,UPPER BEARING 141	182352	RB-141E
SPACER,MOTOR BASE	182704	HMPC-28
SPRING,COMP .25 X .03 X .63	183045	XIC0905F
SPRING,COMP .25 X .03 X .88	154643	HMPC-90
SPRING,COMP 1/2 X X 4-1/2	191097	HMPC-56A
SPRING,RELAY HOLDDOWN	183375	
SPROCKET,1/4P,15T,3/8 BORE	183991	HMPC-111
SPROCKET,3/8P,11T,3/8 BORE	183672	HMPC-68
SPROCKET,3/8P,13T,1/2 BORE	183804	HMPC-88
SPROCKET,3/8P,16T,1-1/8 BORE	184057	HMPC-63
SPROCKET,3/8P,24T,1/2 BORE	196443	
SPROCKET,ADJ CHUTE CHAIN	183760	PO-384-120
STRAP,CAPACITOR	180416	3X654
SWITCH,OVER TEMP	185003	HMPC-134
TUBE,1/4 IN HI TEMP	186961	HMPC-132
WASHER, FELT .25 X .63 X 1/16	198236	
WASHER,PLOW BRACKET	187687	PO-329
WASHER,POT BRACKET LOCK	187698	HMPC-104
WASHER,SHAFT	187709	HMPC-78
WHEEL,GLUE POT	187874	HMPC-69
WHEEL,HAND	187896	HMPC-77
WIPER,GLUE WHEEL	188017	HMPC-71
WIRE,16AWG/3C BLK SJOW	149902	NONE

